

NEW UNIVERSAL RULE OF MEASUREMENT
A PROPOSED REVISION TO THE MEASUREMENT RULE



CLASS M

Version 10.1.0

NEW UNIVERSAL RULE OF MEASUREMENT

CLASS M

Version 10.1.0

INTRODUCTION TO VERSION 10.0.0

This proposed new version of the Universal Rule of Measurement takes into account development work done over a number of years, incorporating what has been learned about this kind of boat from that work, and also from considerations of desired handling characteristics. This proposed version of the measurement rule is far more restrictive than the original, and is intended to produce modernized hulls of the same general type and character as the original class, though keels and rigs are allowed to depart from traditional forms by a greater amount.

It should be noted that this version envisions only boats built to Class M. Hence certain equations and especially constants therein will be found totally inapplicable to other sizes of boats.

Version 9.0.0 was a major new version, changing minimum counter angle and maximum Quarter Beam Length without Penalty. Version 9.0.1 makes several small changes to the interior accommodations requirements, as experience shows that more variation is needed to permit a truly wide variety of acceptable concepts and designs to be used under the rule. Version 10.0.0 further adjusts the QBL maximum without penalty based on further design evaluation, and also changes the method of bridging of hollows in vicinity of measurement points (other than those at the forward end of the profile at the waterline) to bring those bridges into closer conformity with the older Universal Rule of Measurement.

CHANGES FROM VERSION 9.1.0

- Maximum AFT dimension without penalty reduced to $0.12 * LWL$.
- Maximum Quarter Beam Length without penalty reduced.(see equation (6)).
- Method of bridging hollows in the surface of measurement points revised.

CHANGES FROM VERSION 10.0.0

- Added changes in AFT and QBL maximum without penalty to correspond to those for the English system of units. That change had been omitted in 10.0.0.

This Page Deliberately Left Blank

INQUIRIES ABOUT THE RULE

Inquiries about this rule should be addressed to info@universalrule.com.

TERMINOLOGY INDICATING MANDATORY OR ALLOWABLE

Throughout this measurement rule, the term “shall” is taken to mean mandatory, while the term “may” is taken to mean allowable but not mandatory.

MULTIPLE MEASUREMENT CERTIFICATES

A boat measured under this measurement rule shall have only one valid measurement certificate at a given time. That is, if any change in ballast, flotation, sail plan, hull form, keel form, rudder configuration or any other factor requiring re-measurement is made to the boat, then the re-measurement must be physically performed and a new measurement certificate covering the new configuration must be issued. Issuing of that new certificate automatically voids the old certificate, such that the boat, if returned at some point to the earlier configuration, must then be re-measured and yet another new certificate must be issued for the configuration to which the boat was returned.

It is never legal to change back and forth between configurations requiring remeasurement without actually performing the re-measurement.

EXOTIC MATERIALS LIMITATIONS

Exotic materials are taken to be materials having a tensile strength greater than that of the highest tensile strength stainless steel in common use, which is taken to be a yield strength of 30,000 psi. If a material is considered to be totally incapable of plastic deformation, then the rupture strength would be used for this purpose.

At the time of implementation of this version of the rule, only the following items are permitted to be of exotic materials:

- masts;
- spreaders, cranes, and other rigging elements generally attached to the mast;
- booms, and rigging elements generally attached to the boom;
- spinnaker booms and reaching struts;
- transverse rigging.

SUPPLEMENTS TO THE RULE

In this or any measurement rule, there are a vast number of questions which can arise, which cannot all be covered in the Measurement Rule. For this reason, we have included the Supplements to the Measurement Rule, which contain clarifications, explanations and interpretations. These clarifications do not necessarily work the same way as the Rule itself. Some may not set absolute limits, but rather set limits or provide interpretations which are not to be exceeded with a penalty as a part of the Rule itself might be, but rather are to ensure good appearance of the boat or prevent extreme shapes.

In these situations, the Supplement itself will provide the proper information as to whether a limitation is a rigid limit, not to be exceeded at all, or a guideline, not to be exceeded deliberately, but where an insignificant excess or deficiency would be permissible when it is reasonable to assume that the excess or deficiency resulted from error or building tolerance in a boat which was intended to be built right to the particular limit in question, but not intended to exceed it.

TABLE OF CONTENTS

Guiding Principle for Determining Design Legality	8
Class Rating	8
Basic Rating Formula	8
Length Formulas	8
Maximum & Minimum LWL & Measurement of B	9
Penalties Added to L	
Quarter Beam Length	9
Forward Breadth	10
Aft Breadth	10
Displacement	11
Beam	11
Draft	12
Freeboard	12
Sail Area	
Sail Area Formula	13
Limitations on Hull Form	
General Description	13
Multiple Hulls & Outriggers	13
External “Hulls”	13
Flexible Hulls	14
Surface Roughness	14
Overhang & Length Requirements	14
Hull / Deck Radius	14
Hollows in Hull Profile	15
Angles of Stem & Counter	16
Free Flooding Tanks, Water Ballast, etc.	16
Tumble Home	16
Limitatons on Sail Construction & Sail Plan	
Sail Construction	16
Maximum Height of Sail Plan	16
Minimum Height of Boom Above Sheer	16
Maximum Girth of Mainsail	18
Maximum Size of Mainsail Headboard	18
Maximum Height of Fore Triangle	18
Maximum Height & Shape of Spinnaker	18

Length & Construction of Spinnaker Pole	18
Minimum Weight & Construction of Mast	18
Transverse Rigging & Head Stay	19
Dimensions & Construction of Boom	19
Luff Groove Devices & Sail Attachment	19
Loose-Footed Mainsails	19
Limitations on Appendages	
Characterization of Appendages	19
Rudders	19
Skegs	20
Centerboards & Daggerboards	20
Keels	21
Trim Tabs	21
Winglets	21
Legal Appendage Configurations	22
Appendage Construction Requirements	
Basic Keel Construction	22
Hybrid Keel Construction	23
Fairing Rudder Connections to Keel or Skeg	23
Keel Attachment to Hull	23
Fairing the Keel into the Hull	24
Protected Designs & Design Concepts	24
Minimum Construction Requirements	
Scope & Proper Interpretation of Scantlings	25
Materials & Methods of Construction	25
Construction Requirements: English Units	
Minimum Construction Requirements	26
Minimum Weight of Rudder Stock	28
Interior Arrangement & Related Requirements	
Deck Houses	29
Interior Arrangements	29
Deck Layout & Related Requirements	
Cockpits & Cockpit Areas	29
Engine & Propeller Requirements	
Engine Requirements	30
Propeller Requirements	30
Crew Limit	
Crew & Observer Limits	30

Construction & Measurement: Metric Units	
Rating Formulas	31
Minimum Construction Requirements	36
Construction Drawings & Diagrams	
Example Construction Plan	39
Appendix 1: Legality of Designs Under this Rule	
Discussion of Legal Hull Forms	41
Lines of Hull 66F2b	42
Appendix 2: Calculation of PIPA	
PIPA Parameters	43
PIPA Formulas	43
Appendix 3: Special Rules for Exterior Decorum	44
Appendix 4: Parameter Limits Listing, English Units	45
Appendix 5: Parameter Limits Listing, Metric Units	47

GUIDING PRINCIPLE IN DETERMINATION OF LEGALITY OF DESIGNS

The guiding principle in making a determination about the legality of some particular hull design or proposed hull design under this rule, is whether or not the concept in question will continue the kind of boat, appearance of the boat, and performance of the boat in the tradition of the class. Changes which simply carry forward the kind of design progress which has been seen in previous boats is encouraged, while totally new and different shapes are discouraged unless allowed by some provision of this rule or its appendixes.

This rule contains the lines of a “demonstration” M-boat, identified as “Hull 66F2b”. This boat illustrates in a general way what we expect a modern M-boat to be like. Any feature incorporated in the demonstration boat, or any feature which is simply an extension of any such included feature, is deemed to be legal and suitable, regardless of historical foundation. However, in case of apparent conflict, the wording of the “Limitations” sections of this rule take priority over the Hull 66F2b drawing and over historical consideration.

A similar situation exists with appendages, except that in the case of appendages, the date range is any date prior to September 1983. See APPENDIX 1 for a more thorough discussion.

CLASS RATING FOR UNIVERSAL RULE CLASS M

The class rating for Universal Rule Class M shall be 46.00 feet.

BASIC RATING FORMULAS

The basic rating formula for the Universal Rule of Measurement is:

$$R = 0.18 \frac{L\sqrt{S}}{\sqrt[3]{D}}$$

Where:

- R = Class Rating in Feet;
- L = Rated Length in Feet;
- S = Rated Sail Area in Square Feet;
- D = Rated Displacement in Cubic Feet.

LENGTH FORMULAS

The formulas for determining Rated Length are:

$$L = LWL + P_{qbl} + P_{fwd} + P_{aft} + P_{disp} + P_{beam} + P_{draft} + P_{fbd} \quad (2)$$

Where:

- L = Rated Length In Feet;
- LWL = Water Line Length in Feet, in Measurement Trim
- P_{qbl} = Quarter Beam Penalty in Feet;
- P_{fwd} = Excessive Breadth of Section Penalty at Forward End of LWL in Feet;
- P_{aft} = Excessive Breadth of Section Penalty at Aft End of LWL in Feet;
- P_{disp} = Insufficient Actual Displacement Penalty in Feet;
- P_{beam} = Excessive or Insufficient Breadth Penalty at Maximum Beam Station in Feet;
- P_{draft} = Excessive Draft Penalty at the Maximum Draft Station in Feet;
- P_{fbd} = Insufficient freeboard Penalty in Feet.

MAXIMUM & MINIMUM LWL AND MEASUREMENT OF B

The LWL shall be the length, at the line of flotation with the boat in measurement trim, from the forward most point of immersion to the after most point of immersion. The beam B shall be the greatest width of the line of flotation, measured in the transverse plane. See FIGURE 1.

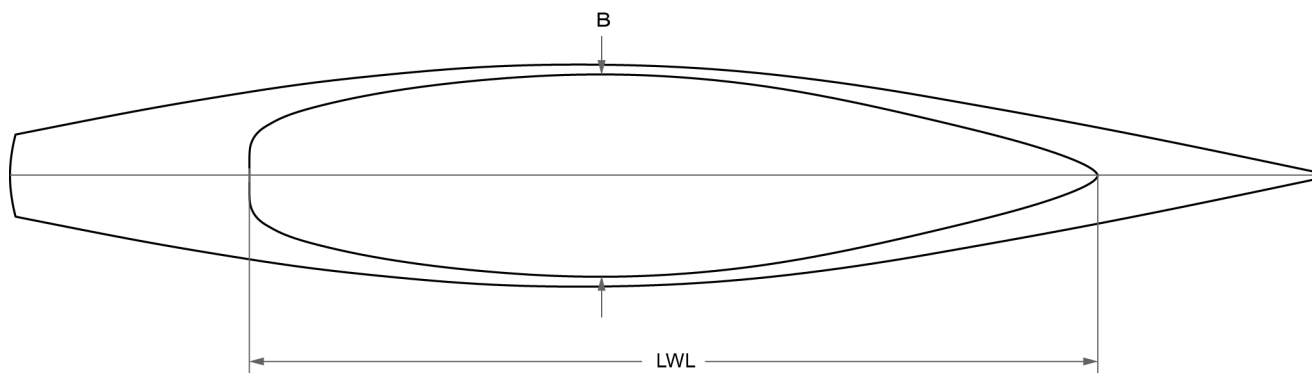

FIGURE 1. MEASUREMENT OF B AND LWL

The Maximum LWL in Measurement Trim shall be:

$$LWL_{\max} = (1.08 * \text{Class Rating}) + 5.0 \text{ ft.} \quad (3)$$

The Minimum LWL in Measurement Trim shall be:

$$LWL_{\min} = (1.08 * \text{Class Rating}) + 3.0 \text{ ft.} \quad (4)$$

If any point on the hull, below the LWL, lies further forward than the forward end of the LWL, then a vertical projection of that point up to the surface of the water shall be taken as the forward end of LWL for all purposes under this rule. Nothing in this section shall be taken to imply any exception to the limitations on hull profile in the Limitation on Hull Forms section below.

If any point on the hull, below the LWL, lies further aft than the aft end of the LWL, then a vertical projection of that point up to the surface of the water shall be taken as the aft end of LWL for all purposes under this rule. Note that the rudder is not considered to be a point on the hull for purposes of this section of the measurement rule.

The Beam, B, shall be the maximum breadth of the water line plane when the boat is in measurement trim.

PENALTIES ADDED TO LENGTH L

Quarter Beam Length

The quarter beam length, QBL, shall be the length of the boat measured in the water plane parallel to the LWL in measurement trim, and measured parallel to the centerline of the boat, at a height B/10 above the LWL, and at a breadth B/4 from fore / aft the centerline of the boat.

The maximum quarter beam length without penalty shall be:

$$QBL_{\max} = \frac{100 - \sqrt{LWL}}{100} * LWL + 2.40 \quad (5)$$

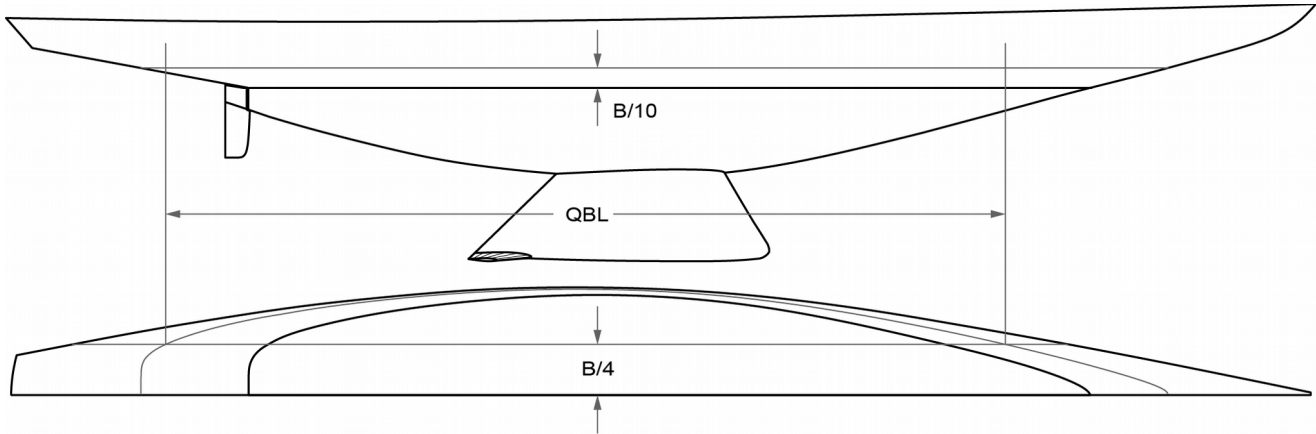

FIGURE 2. QUARTER BEAM LENGTH

If the quarter beam length is greater than the maximum permitted without penalty in (5), the quarter beam penalty shall be given by:

$$P_{qbl} = 0.5 \left[QBL - \left(\frac{100 - \sqrt{LWL}}{100} \right) * LWL \right] - 1.20 \tag{6}$$

The forward end of QBL shall not be taken as further aft than 0.12 * LWL aft of the forward end of LWL.

Forward Breadth

The forward breadth, FWD, shall be the breadth of the boat measured in the transverse plane at the forward ending of LWL, taken at a height of 0.400 ft (122 mm) above LWL.

The maximum forward breadth without penalty shall be:

$$FWD_{max} = 0.04 * LWL \tag{7}$$

If the forward breadth as defined above is greater than the maximum allowed without penalty in (7), the penalty shall be given by:

$$P_{fwd} = 2 * (\text{actual forward breadth} - (0.04 * LWL)) \tag{8}$$

Aft Breadth

The aft breadth, AFT, shall be the breadth of the boat measured in the transverse plane at the aft ending of LWL, taken at a height of 0.400 ft (122 mm) above LWL.

The maximum aft breadth without penalty shall be:

$$AFT_{max} = 0.12 * LWL \tag{9}$$

If the aft breadth as defined above is greater than the maximum allowed without penalty in (9), the penalty shall be given by:

$$P_{aft} = \text{actual aft breadth} - (0.12 * LWL) \tag{10}$$

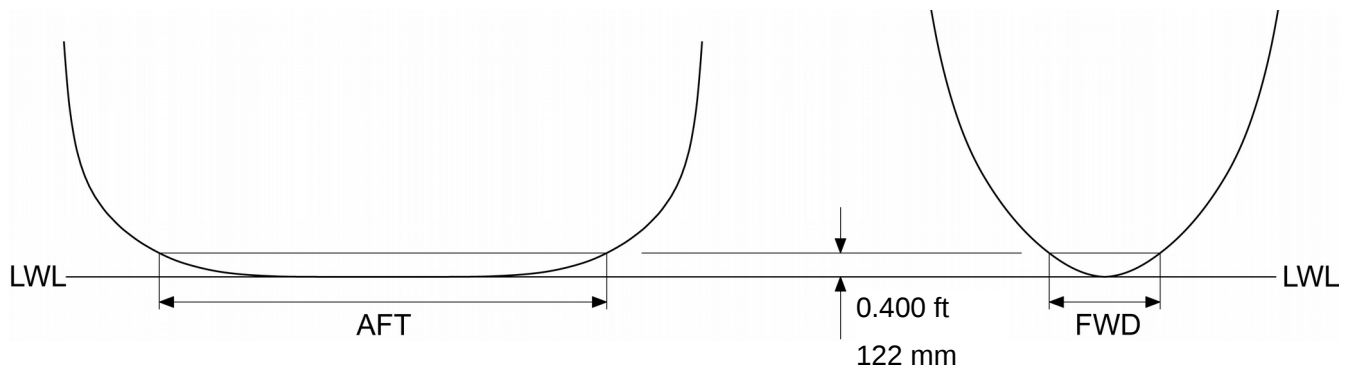

FIGURE 3. FORE & AFT MEASUREMENT

Displacement

The minimum displacement (in cubic feet) without penalty shall be

$$Disp_{min} = (0.2 * LWL + 0.5)^3 \tag{11}$$

If the actual displacement (in cubic feet) is less than the minimum given by (11), then the displacement penalty shall be

$$P_{disp} = LWL - \frac{\sqrt[3]{(actual\ displacement)} - 0.5}{0.2} \tag{12}$$

Rated displacement, D in the rating formula, shall be the actual displacement of the boat as determined by weighing. D shall not be taken as greater than the rule minimum displacement as defined in (11) above. Therefore

$$\sqrt[3]{D} \leq (0.2 * LWL + 0.5) \tag{13}$$

Beam

The Beam, B, as defined above under Maximum & Minimum LWL and Measurement of B, shall be not less than

$$B_{min} = 0.235 * LWL \tag{14}$$

If B is less than the minimum defined in (14), the penalty shall be

$$P_{beam} = 0.235 * LWL - actual\ LWL\ beam \tag{15}$$

The Beam, B, as defined above under Quarter Beam Length, shall be not greater than

$$B_{max} = 0.25 * LWL \tag{16}$$

If B is greater than the maximum defined in (16), the penalty shall be

$$P_{beam} = actual\ LWL\ beam - (0.25 * LWL) \tag{17}$$

Draft

Draft, H, shall be the maximum vertical depth that can be found, perpendicular to the water line plane with the boat upright in measurement trim, from the water line plane to the lowest point on the boat or any extension thereof or on any appendage attached thereto. Note that the maximum depth might not lie on the transverse centerline of the boat.

The maximum draft as defined just above shall be

$$H_{\max} = 0.16 * LWL + 2.56 \text{ ft} \quad (18)$$

If the draft exceeds the maximum defined just above, the penalty shall be

$$P_{\text{draft}} = 3 * (\text{actual draft} - (0.16 * LWL + 2.56)) \quad (19)$$

Freeboard

The sheer line shall be a fair, continuous concave curve, from stem head to transom. The Freeboard, F, shall be the vertical height from the line of flotation to the top of the deck or rail at the appropriate fore / aft location.

The freeboard taken in measurement trim at the midship (50% LWL) station shall be not less than

$$F_{\min} = 0.062 * LWL + 0.6 \text{ ft} \quad (20)$$

The freeboard at the forward end of LWL, in measurement trim, shall be not less than

$$F_{\min \text{ fwd}} = F_{\min} * 1.179 \quad (21)$$

and the freeboard at the aft end of LWL, in measurement trim, shall be not less than

$$F_{\min \text{ aft}} = F_{\min} * 0.979 \quad (22)$$

If any of the above 3 freeboard measurements is less than the minimum required, the penalty shall be

$$P_{\text{fbd}} = 2 * (F_{\text{rqd}} - F_{\text{act}}) \quad (23)$$

where:

F_{rqd} = Freeboard required at that station from (20), (21), or (22) above;

F_{act} = Actual freeboard at that station.

If more than one of the measured freeboards is less than the required minimum, the penalty shall be based on the largest deficiency, not the sum of the deficiencies.

Decks shall not have “negative camber”, that is the deck shall not get lower when one moves from the edge of the deck toward the centerline. The maximum deck camber shall be 7.5 inches (190 mm).

There shall be no winches below deck, nor shall anyone stand in a hatch to operate a winch or tail a line from the winch.

SAIL AREA

Sail Area Formula

Rated sail area, S, in the rating formula shall be the triangular area of the mainsail plus 85% of the area of the fore triangle, that is

$$S = \frac{P * E}{2} + 0.85 \frac{I * J}{2} \quad (24)$$

Where:

- P = Mainsail luff length in feet;
- E = Mainsail foot length in feet;
- I = Fore triangle height in feet, taken from the sheer line abreast the mast;
- J = Base of fore triangle in feet.

LIMITATIONS ON HULL FORM

General Description

Boats designed to this measurement rule shall be of a narrow, deep, form with long, relatively low, overhanging ends. The following stipulations are specifically included:

Multiple Hulls & Outriggers

Configurations with multiple hulls of any kind are prohibited. The basic test of this shall be that the longest length measurement, on the centerline plane, shall be on the transverse centerline itself, and shall be taken to points on the actual hull, not on extensions or interpolations of same. In similar manner, the maximum depth of the hull at any transverse section shall be on the transverse centerline, and shall also be to a point on the physical hull, not to extensions or interpolations thereof. Thus, catamarans are illegal. Where a cross section is flat or nearly flat, near the centerline of the boat, a tolerance of 1/8 in. (3 mm) is permitted such that an unintended depth of hull off the centerline not more than 1/8 in (3 mm) in depth is not considered to contravene this rule.

There shall be no outriggers of any kind attached to the hull, or suspended above or alongside or below it. For this purpose an outrigger is a device which supports a pontoon or other object(s) which may, at some angle of heel or other orientation of the boat, touch or become immersed in the water. Thus, trimarans are illegal.

There shall be no device for positioning the crew outboard of the edge of the deck of the boat, or outboard of a vertical extension of the deck of the boat, with the boat upright. A small cap strip on top of a bulwark is not an outrigger for purpose of this paragraph, provided that it extends no further than 1 ½ in. (38 mm) outboard of the outer surface of the bulwark. Likewise, a tapered chafing sleeve for mooring lines may extend outside the hull through a drain hole in the rail, but it also shall not extend further than 1 ½ in. (38.1 mm) beyond the edge of the hull.

Bowsprits, and similar devices at the stern of the boat, are prohibited.

External “Hulls”

There shall be only one hull. No appendage shall be configured such that it simulates a hull, and – except for one rudder which is mounted at the aft end of LWL – no appendage shall increase the waterline length or the sailing length of the boat. There is no legal configuration in which there is a hull, or part of a hull, inside of another hull or part of a hull.

Flexible Hulls

The hull of the boat shall be essentially rigid, and fixed in shape. No flexible skin, fluid-filled skin, or other methodology shall be used to make it possible to alter the shape of the hull, other than by standard rebuilding methods during a major alteration of the boat.

Surface Roughness

No material shall be added to the hull for the purpose, or with the effect, of adding roughness to the surface of the hull or keel, except that a strip 1.00 ft (305 mm) long, measured parallel to the line of flotation, and beginning at the leading edge of the stem of the boat and / or the leading edge of the keel, may be made rough by means of adding ground shells or other material to the bottom paint.

This section shall not be construed so as to prevent flat plates or pegs or similar devices from being used as turbulence generators along portions of the keel or other appendages.

Turbulence generators, other than the additions to paint described in the previous paragraphs, shall not be used on the hull.

For purposes of surface roughness as addressed in this section, the deck is not part of the hull.

Overhang & Length Requirements

The minimum forward overhang of the boat, when in measurement trim, shall be 14.25 ft (4.343 m), measured in the horizontal plane, from the forward most ending of LWL, in measurement trim, to the stem head, neglecting any fitting or attachment on or over the stem head. The minimum overall length of the boat, measured in the horizontal plane from the stem head as defined herein, to the farthest aft point on the transom or stern overhang, shall be 84.25 ft (25.679 m).

Unless it is double-ended, the boat shall have a transom. The transom, if it slopes aft as freeboard increases, when measured at the transverse centerline, shall make an angle with the vertical not less than 40 degrees. A transom which slopes forward as freeboard increases (reverse transom), shall make an angle to vertical not greater than 40 degrees. Where a reverse transom is used, special transom construction regulations apply so that no significant advantage in weight or weight distribution is achieved. A transom is always part of the hull, not part of the deck.

Hull / Deck Radius

The maximum radius of the side of the boat to the deck shall be 3/16 in (4 mm).

Hollows in Hull Profile

There shall be no hollows in the deck planform (ie. top view profile).

There shall be no hollows in the profile of the hull between the sheer line and the LWL in measurement trim. Below the LWL, and forward of a transverse station 10% of LWL abaft the forward end of LWL, there shall be no double inflections in profile shape, that is, the stem profile between the forward end of LWL and the 10% LWL station aft of the forward end of LWL, may be straight, convex or concave, but shall not be a combination of convex and concave.

Drawing A at right shows a straight stem below LWL.

Drawing B at right shows a boat with a stem which is hollow (concave) below the LWL.

Drawing C at right shows a stem which is convex below the LWL.

All of the above are legal configurations.

Drawing D at right shows a stem with a bulge in it, that is, it is hollow (concave), then reverses the curvature to be convex, both below LWL but forward of a Station 10% of LWL aft of the forward ending of LWL. The form in Drawing D is illegal.

To allow for transitions from convex above the LWL to concave below the LWL, a tolerance of ¼ in (6.35 mm) is permitted on the double-inflection portion of this rule. That is, if a double-inflection has no convex portion or concave portion greater than ¼ in (6.35 mm) in the area in question, then it is allowed.

See FIGURE 4. See also the section which follows.

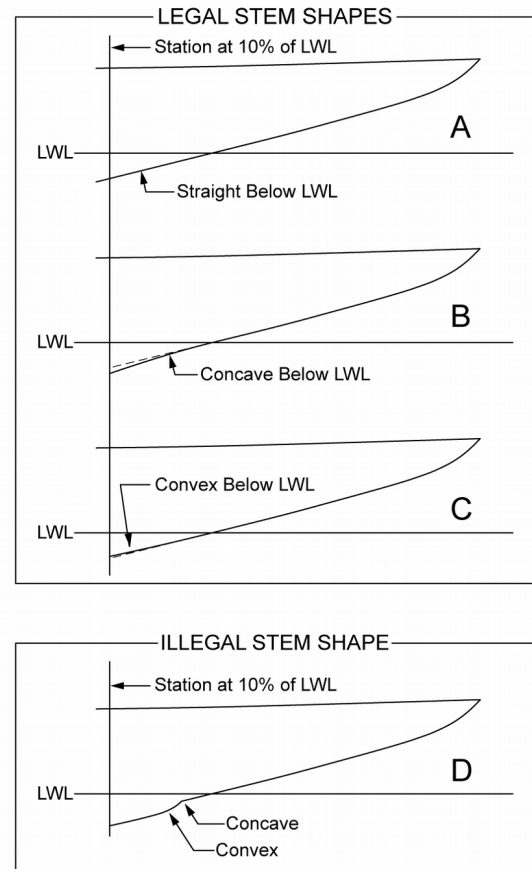

FIGURE 4. LEGAL & ILLEGAL STEM SHAPES

A straight-edge shall be placed on the stem from a point located on the stem at a horizontal distance of 3.5% of LWL forward of the forward end of LWL, and extending along the stem to a point on the stem a horizontal distance of 3.5% of LWL aft of the forward end of LWL. Any hollow lying within that portion of the stem shall be bridged as described, and a new value of LWL established from the aft end of the original LWL to the point where the water plane established by the original LWL intersects the bridge. The bridged value of LWL shall be used for calculating the measured Length and for calculating the minimum displacement. All other functions of LWL shall be calculated using the non-bridged value of LWL.

Except at the aft end of the LWL, if any hollow in the surface of the hull occurs at or near a measurement point [i.e. within 1 ft (304.8 mm) above and 1 ft (304.8 mm) below the measurement point, and/or one-third of B forward and/or one-third of B aft of the measurement point], that hollow shall be bridged with a straight edge whose length is one-third of B, and whose center is at the measurement point within the hollow area. Hollows shall be bridged in both the buttock and the waterline plane of the measurement point, and whichever measurement gives the greater result shall be used in the determination of QBL.

The same methodology applies at the aft end of the LWL, except that the bridging forward of the aft end of the LWL is not to be done below the + 1' 4" (+ 406.4 mm) waterline.

Angles of Stem and Counter

The minimum angle between the stem and the LWL, taken at the intersection of the stem and the LWL when the boat is in measurement trim, shall be 12.90 degrees. The minimum angle between the counter and the LWL, taken at the intersection of the counter and the LWL with the boat in measurement trim, shall be 9.75 degrees. Any deficiency is to be added to the rating R, 0.1 ft. for each 0.1 degree etc., interpolated to find the penalty for deficiencies which are not exactly tenths of a degree. See Figure 5.

Free Flooding Tanks, Water Ballast, etc.

There shall be no free flooding tanks. Water or other fluids shall not be carried on board for the purpose of acting as ballast, and if carried, shall not be shifted by any manner other than by the natural force of gravity while the boat is underway, except that the fluid in such a tank may be used for its intended purpose(s), for instance water in a water tank may be consumed or used for cooking, washing, etc.

Tumble Home

The maximum tumble home, if any, on each side of the boat, shall be not greater than 0.32 ft (97.5 mm). Any excess shall be added to the rating, R. Tumble Home shall be taken as the difference, in the vertical plane of any transverse section, between the maximum beam at any vertical height of that section above LWL, and the beam on deck at that same transverse section.

LIMITATIONS ON SAIL CONSTRUCTION & SAIL PLAN**Sail Construction**

Sails shall be made of a form of “cloth”, that is, they shall not be rigid wings or foils. Sails shall be constructed of a material such that the sail may be folded loosely into segments not greater than 3 ft (0.914 m) in width. Provided that the sail can be folded in this manner, it may be constructed of any material, including kevlar, mylar, carbon fiber, Dacron, or any combination of these. The purpose of the term “loosely” in this section is to require that the sail be of a cloth-like material rather than a rigid wing configuration, not to require that the sail be creased which would potentially damage the threads or other flexible materials from which it is constructed.

Double-luffed sails or sails which in any way wrap around any spar(s) are prohibited.

Maximum Height of Sail Plan

The maximum height of the sail plan above the sheer line, measured along the aft edge of the mast (not necessarily vertical), shall be given by

$$\text{Rig Height}_{\max} = 1.85\sqrt{S} + 5.0 \quad (25)$$

Minimum Height of Boom Above Sheer

The minimum vertical height of the lower measurement point of mainsail luff P above the sheer line of the boat, abreast the aft edge of the mast, shall be 6.00 ft (1.828 m).

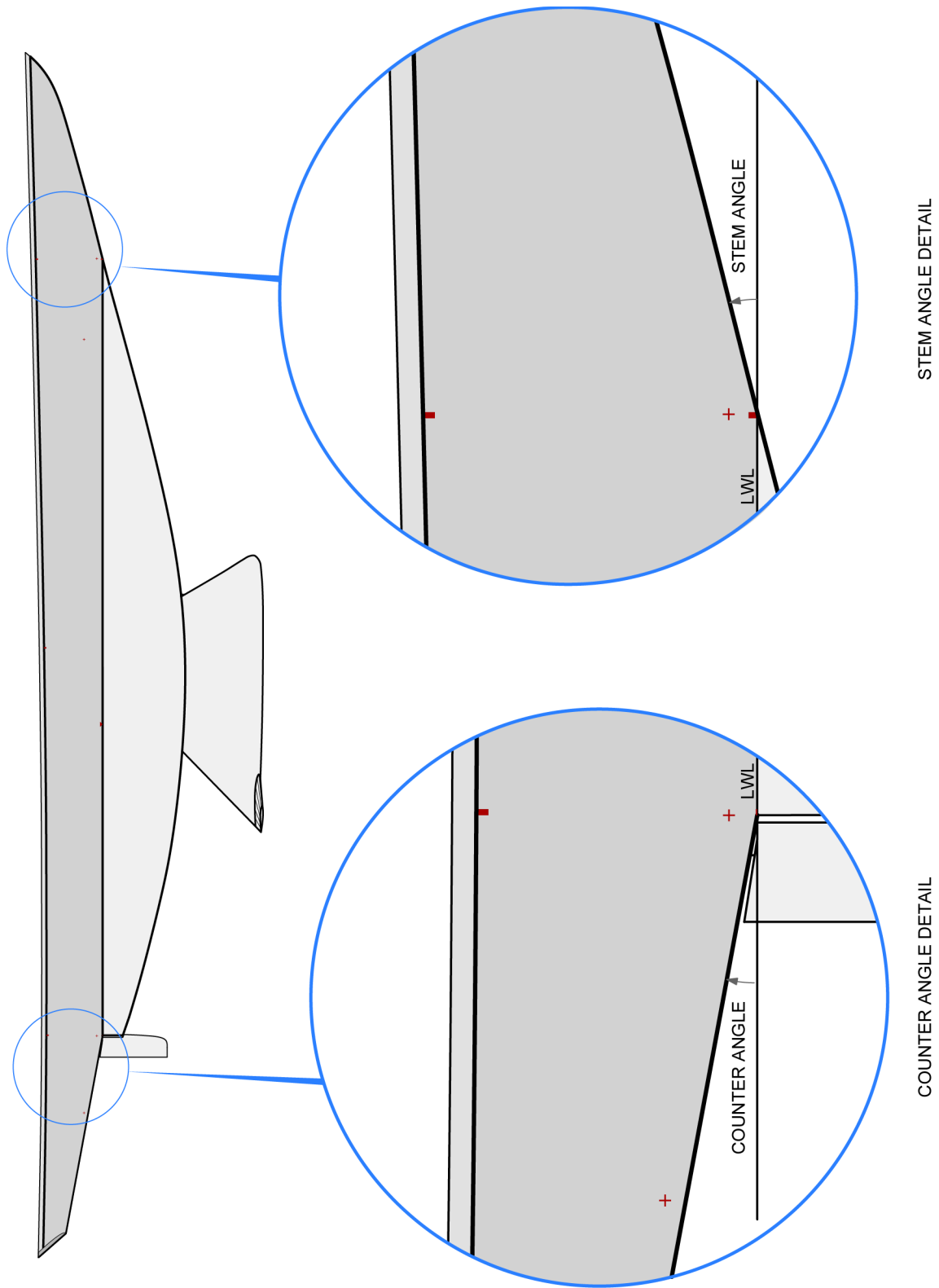

FIGURE 5. STEM AND COUNTER ANGLE MEASUREMENT

Maximum Girth of Mainsail

The maximum dimension of the mainsail, measured perpendicular to the luff at a height 65% of P above the base of P, shall be

$$\text{Girth}_{\text{max}} = 0.56 * E \quad (26)$$

The leech of the mainsail shall lie on a fair continuous convex curve drawn through the headboard, the boom black band, and the outboard end of each batten. Small flat spots or hollows between battens, used solely to make the leech of sail stand properly, do not violate this rule, but the girth maximum shall be taken to a fair curve through the battens, even if that curve lies off of the sail.

Maximum Size of Mainsail Headboard

The maximum horizontal length of the top of the mainsail headboard abaft the aft end of the mast shall be 1.40 ft (0.427 m). No part of the headboard shall be longer than a fair interpolation of the top length and the girth and foot of the mainsail.

Maximum Height of Fore Triangle

The maximum height of the fore triangle above the sheer line, measured along the leading edge of the mast (not necessarily vertical) shall be 82.5 ft (25.146 m).

A jib is taken to be any sail which is set within the fore triangle of the boat, except that a jib may extend aft of the mast. Jibs may be of any planform shape, but may not have battens and may not have headboards. Exception: jibs which do not at any point overlap or extend aft of the mast may use up to 5 battens in the leech, provided the battens are not longer than 5 ft. (1.524 m) in length, and are not more than 3 in (76.2 mm) in width.

Maximum Height and Shape of Spinnaker

The maximum height of the spinnaker halyard above the upper measurement point of I shall be not greater than 0.50 ft (152.4 mm). Spinnakers may be of asymmetrical or symmetrical shape.

Length and Construction of Spinnaker Pole

The maximum length of spinnaker pole shall be not greater than $1.10 * J$. Spinnaker pole(s) may be constructed of aluminum, steel, wood, fiberglass, titanium, carbon fiber, kevlar, or any combination thereof.

Minimum Weight and Construction of Mast

The mast shall have a minimum weight of 850 lbs (385.5 kg), including all spreaders and fittings, but excluding running and standing rigging. The vertical center of gravity of the mast, when in measurement condition, shall be not lower than 37.5% of the maximum height of sail plan above the sheer line. The minimum weight is to ensure good racing, and does not guarantee the safety of the mast or rigging. It remains the responsibility of the designer, builder, and spar maker to ensure that the mast and rig are adequate for the purpose. The mast may be made of aluminum, steel, wood, fiberglass, kevlar, carbon fiber, titanium, or any combination thereof. All other materials are prohibited.

The mast shall be stepped either on or just above the keel / stem centerline structure of the boat, and shall be fixed athwartship such that the base of the mast may not move from side to side. The deck partners shall have only the opening width required to properly pass the mast through, in no case more than 0.75 in (19 mm) on each side of the mast, such that the mast is effectively prevented from moving from side to side at the deck. The mast may be free to move forward / aft at the deck, but the base of the mast shall be fixed in the forward / aft direction. The maximum motion of the mast forward / aft at the deck shall be 0.333 ft

(101.6 mm). Hydraulic rams and other mechanical devices may be used to move the mast forward / aft at the deck, or to constrain the mast from moving forward / aft at the deck. Where the mast is permitted / caused to move at the deck, the “J” dimension shall be taken with the mast in its aft-most deck position.

Masts which tilt from side to side, other than that which occurs naturally due to stretch in rigging, etc., and masts which consist of a structure other than a single spar supported by rigging with spreaders, are prohibited. Rotating and permanently bent masts are prohibited. A small permanent bend of less than 0.667 ft (203.2 mm), which is incidental and not deliberately built into the mast, is acceptable.

Spreader may be made of aluminum, steel, wood, fiberglass, titanium, carbon fiber, kevlar or any combination thereof.

Transverse Rigging & Head Stay

Transverse rigging, that is shrouds, and the head stay, shall not be adjusted during a race, except if an emergency situation arises which requires making such an adjustment. If that occurs, the boat shall report the situation and the action taken to the Race Committee and / or Rules Committee for their decision whether the action taken was in fact warranted. Transverse rigging may be of steel, titanium, kevlar or carbon fiber. All other materials are prohibited, but sheathing, if used, may be of any material. Headstays may not be of exotic materials.

Dimensions and Construction of Boom

The boom shall have a maximum width of 2.50 ft (762 mm), measured in the transverse plane and horizontal. The maximum vertical depth of the boom shall be not greater than 1.375 ft (419 mm).

The boom may be constructed of aluminum, steel, wood, fiberglass, titanium, carbon fiber, kevlar, or any combination thereof. All other materials are prohibited.

Luff Groove Devices

Luff groove devices for jibs are prohibited. All jibs must be attached to the head stay or a fore stay by means of pull-pin hanks, twist hanks, Velcro wrap-around straps, or other similar methods. All mainsails must be attached to the mast by means of slides running along a track, or by means of slugs running inside a tunnel. The mast cross-sectional shape may be such that the track is essentially internal.

Loose-Footed Mainsails

Loose-footed mainsails are prohibited. “Park Avenue” booms and mechanically bent booms are permitted.

LIMITATIONS ON APPENDAGES

Characterization of Appendages

Appendages are items which protrude from the hull or from another appendage, and which carry out at least one of their functions by means of aerodynamic lift, drag, etc.

Appendages may be broken down into different groups, whose limitations will be set as a function of which group they fall into:

Rudders: the main function of a rudder is to steer the boat. Typically a rudder rotates about some post which is vertical in the transverse plane, thus creating a difference in lift on each side of the rudder which has the effect of turning the boat. A rudder may also generate lift which resists the side force generated by the sail plan of the boat; this is not the main function of the rudder, but does not disqualify the rudder from being deemed a rudder.

A rudder may be attached to a skeg or keel. A rudder must be mounted on the transverse centerline of the boat. A rudder may be mounted above the LWL if and only if the rudder post is entirely aft of the aft end of the LWL, and only if it is on the transverse centerline and is vertical in the transverse plane. A rudder mounted in this manner may not have its leading edge, or the leading edge of the post about which it rotates – whichever is further aft – further aft than 0.125 ft (38.1 mm) aft of the after end of LWL. Where any portion of the rudder is above the LWL with the boat upright in measurement trim, the longest horizontal length of the rudder above the LWL shall be 1.64 ft (499.8 mm), and the trailing edge of the rudder must not slope aft so as to increase the length of the rudder below the LWL.

A rudder shall not be deeper (below the LWL) than 0.5 times the rule maximum draft of the boat, that is the rudder shall have a maximum depth below the LWL of

$$\text{Rudder Depth}_{\max} = 0.5 * H_{\max} \quad (27)$$

Where:

H_{\max} = maximum draft without penalty per (18) above.

Exception: if a rudder is the only movable appendage except for a centerboard or daggerboard, and if the rudder is attached to the trailing edge of the keel, then the rudder may be any depth provided that the rule draft (equation 18 above) is not exceeded.

Rudders may be made of aluminum, steel, wood, or fiberglass, or any combination thereof. If made of fiberglass, the mechanical characteristics of the laminate may not exceed that of S-Glass.

Skegs: the main function of a skeg is to direct fluid flow along the after underbody of the boat toward the rudder. A skeg may be classed as a skeg if and only if there is a rudder attached to it and operating in its immediate wake.

Centerboards and Daggerboards: a centerboard is a device which protrudes from the bottom of a keel, and which is raised and lowered by means of rotation about some point, usually at or near the leading edge of the centerboard. A daggerboard is a device which protrudes from the bottom of a keel, and which is raised and lowered by means of lifting up on it causing it to slide up and down. Hence is centerboard rotates about some point, while a daggerboard translates vertically. Centerboards and daggerboards must operate through a slot in a keel, and must not protrude from the hull instead of a keel. The keel slot through which the centerboard or daggerboard works must be contained entirely within the keel, and not extend beyond the limits of the keel in any longitudinal or transverse direction.

It must always be possible to raise a centerboard or daggerboard high enough that the draft with the centerboard or daggerboard fully retracted does not exceed the Maximum draft as defined in (18) above.

The maximum total exposed lateral area of centerboard(s) and / or daggerboard(s), if any, shall be not greater than

$$\text{Area}_{\max} = 0.42 * \text{LWL} \quad (28)$$

The maximum draft of the boat with the centerboard(s) and / or daggerboard(s) fully extended shall not exceed

$$\text{Total Draft}_{\max} = H_{\max} * 1.43 \quad (29)$$

Where:

H_{\max} = Maximum Draft without Penalty from (18) above.

Centerboards and daggerboards may not be heavier than manganese bronze (518.2 lbs / ft³, or 8300 kg / m³).

Keels: a keel is an airfoil which is attached to the centerline structure of a hull, and serves at least the two primary purposes of:

Holding ballast which keeps the boat upright or more nearly upright than it would be without the ballast; and

Providing lateral resistance, usually developed by means of aerodynamic lift, which acts to counteract the side forces generated by the rig and sail plan.

A Keel must be vertical in the transverse plane when the boat is upright in measurement trim. A keel may have one or more of the following attached to it:

One rudder;

One set of winglets (one winglet per side);

One trim tab (if there is no rudder attached to the keel);

One centerboard, or one daggerboard, but not one of each.

Below a plane parallel to the line of flotation, 6 in (152.4 mm) below the lowest exposed point of the hull, a keel shall have no hollows. This means that the perimeter profile of the keel may not have hollows, nor may any transverse section through the keel. Where necessary, compliance with this provision shall be confirmed by testing with a straight edge. Areas immediately involved in the attachment of a trim tab, or the attachment of winglets, are excepted from this hollows requirement, provided that any such excepted surface is within 6 in (152.4 mm) of the nearest part of the tab or winglet.

In keels where the tip chord is longer than the root chord, the tip chord must be not greater than two times the length of the root chord. Canting and rotating keels are prohibited.

Keels may not be heavier than cast lead (708 lbs / ft³, or 11,341 kg / m³).

Trim Tabs: trim tabs are secondary rudders, mounted on the trailing edge of a keel, which have as a primary purpose to influence the lift generated by the keel by aerodynamic means, and have as a secondary purpose to aid in steering the boat. The difference between a trim tab and a rudder is that a trim can exist only if there is another rudder, and then it has steering as its secondary, not primary, purpose. A rudder always has steering as its primary purpose. Trim tabs may not comprise more than 20% of the total keel chord dimension along any given keel chord.

Trim tabs may be attached to the keel at the bottom extremity of their position, but the mounting must be in the form of support for the trim tab, and must not have a second purpose of altering the shape of the tab or the keel to effectively create a bulb at the tip of the keel or trim tab. The mounting may not increase the depth of the keel or of the trim tab, and the trim tab is at all points restricted to a chord length no greater than 20% of the corresponding keel chord (including the tab).

Trim tabs may not be heavier than cast lead (708 lbs / ft³, or 11,341 kg / m³).

Winglets: winglets are airfoil surfaces mounted to the keel near the bottom of the keel, and projecting outward very approximately perpendicular to the surface of the keel. Winglets must be fixed in orientation; that is they may not rotate, translate, pivot (as to alter sweep angle), etc., in any plane or in any axis.

The maximum span, from winglet tip on one side of the boat, to winglet tip on the other side of the boat, must be not greater than B as defined above in Figure 1. Winglets may have dihedral angles which place the winglet tip lower than the winglet root, but the static draft given by equation 18 above must not be exceeded when the boat is upright in measurement trim. Winglets may not have a thickness coefficient greater than 15%, that is the thickness as a percentage of the chord length must be less than or equal to 0.15.

The ratio of winglet tip chord length to winglet root chord length must be at least 0.25.
 Winglets may not be heavier than manganese bronze (518.2 lbs / ft³, or 8300 kg / m³).

Legal Appendage Configurations

An M-boat shall have one keel and one rudder (which may or may not be connected to each other).
 Optional appendages are limited to:

- One Trim Tab;
- One Centerboard or one Daggerboard, but not both;
- One set of two keel-mounted Winglets (one winglet per side of the keel);
- One skeg (which, in order to be legal, must have a rudder attached to its trailing edge).

Excluding a centerboard or a daggerboard, a maximum of two movable appendages are allowed (one of which is the rudder).

There is no legal configuration in which a series of high aspect ratio foils are used along the fore/aft axis of the boat rather than using one larger keel. There is no legal configuration which uses a bulb at the bottom of a foil or a keel. Canards are illegal. See FIGURE 6.

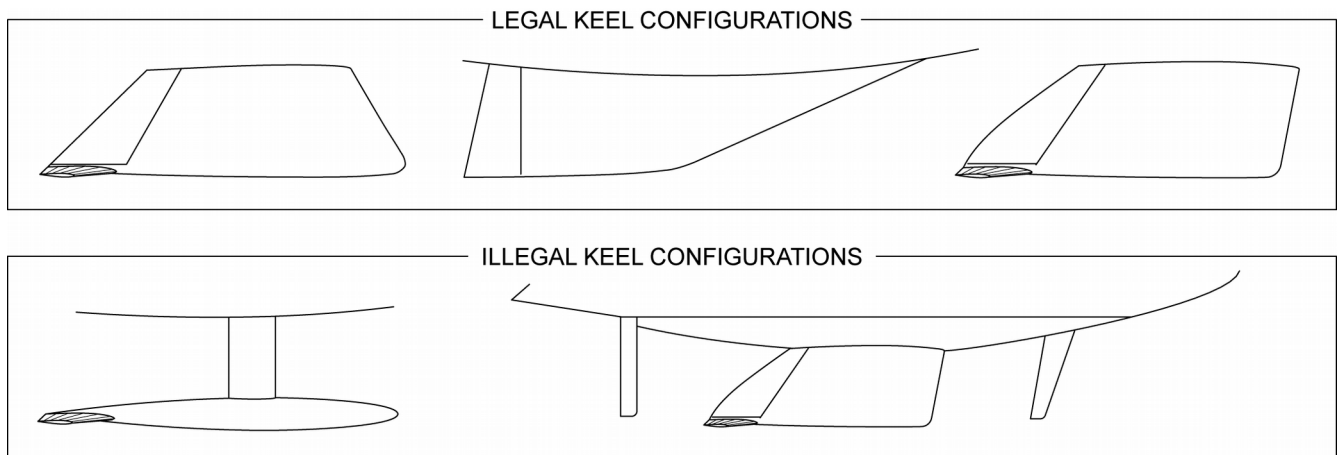

FIGURE 6. LEGAL AND ILLEGAL KEEL CONFIGURATIONS

Appendage Construction Requirements

Basic Keel Construction

Except where the upper portion of a keel must be made of multiple materials, the keel shall be all of one material, normally lead. There shall be no voids in the keel casting, and only those holes or other openings shall be permitted which are there for attachment of winglets or a trim tab, or for attachment of the rudder in a configuration where the rudder is hung from the keel.

Exception: a slot may be cast or cut into the keel to permit use of a centerboard or daggerboard. This slot may be lined with a different material, (e.g. Bronze) if desired. Where a centerboard is used, there is also an exception allowed for the “pin” about which the centerboard rotates in order to be lifted or lowered into position below the keel. Finally, there is an exception for a shallow relief for fairing strips used when the rudder or trim tab is attached to the trailing edge of the keel or skeg (also see “Fairing Rudder Connections to Keel or Skeg” below).

Hybrid Keel Construction

It may happen that the upper portion of the keel must be made of a different material than lead, if for instance, the amount of lead available for the keel is less than is required to make up the size of the keel. In this case the keel shall be built in two stages, where the lower portion is the lead casting complying with all of the above provisions, and the upper portion is another casting, say of aluminum, which also complies with all the previously-stated requirements, the only difference being the material from which this upper casting is made.

Where the hybrid keel construction is utilized, a weldment may be used instead of a separate casting. That is, where the upper portion is an aluminum casting, it would be acceptable to use an aluminum weldment instead of a casting, provided that full allowance is made for the actual welded strength of aluminum which is considerably less than that of a solid (unwelded) aluminum.

In this hybrid keel case, the keel portions must each comply with all the requirements for attaching the keel to the hull, that is:

Each portion of the hybrid keel is connected to the portion physically above it (keel or hull) by means of keel bolts meeting all the requirements for size, number, and strength of keel bolts. Hence, there are two sets of keel bolts, one holding the lead casting to the aluminum casting (or weldment), and the second holding the now bolted-together lead/aluminum keel to the hull;

it is not acceptable to use one long set of bolts to connect the lead to the hull, with the aluminum being sandwiched in between, as there is too much possibility of the pieces moving on each other and working the structure loose.

Exception: where, for purposes of making a hard surface for the keel to bear against when the boat is heeled over, a spacer of a harder material than lead is used between the top of the lead keel and the bottom of the aluminum hull, then one set of bolts may pass through that spacer and into the hull without requirement for a second set of bolts. In this case, the spacer must be solid, not a casting or a weldment, and must be not greater than 2 in (50.8 mm) thick.

Note that, where the nature of the structure is such that the width is very different for one attachment, say hull to aluminum, from the other, aluminum keel to lead keel, the requirements for the keel bolts will also differ greatly, and each connection is to be made with bolts appropriate for that connection.

Fairing Rudder Connections to Keel or Skeg

Where the rudder is attached to the trailing edge of the keel, or the trailing edge of the skeg, it will be necessary to fair the rudder to the keel or skeg (this also applies to the trim tab hung from the trailing edge of the keel). In this case a shallow relief is allowed to be cut into the keel or skeg so that a flexible plastic strip can be set flush into the keel or skeg, then overlapping the rudder or trim tab post to provide a fair transition. Note though that there is a limit to how far aft of the skeg that the rudder post can be located.

Keel Attachment to Hull to Comply with International or Other Standard

Because each case will be different, no single norm for size or strength of keel attachment bolts, etc., is given here. The method chosen, and the dimensions, etc., utilized, shall comply with one of the International standards such as ISO, RINA, Lloyds, or American Bureau of Shipping, or with the new scantlings published by Dave Gerr, *The Elements of Boat Strength*. As they cover both English and Metric units, the standards published by American Bureau of Shipping and in *The Elements of Boat Strength* are particularly convenient to use.

Fairing the Keel into the Hull

Where the keel joins the hull itself, there may be some small areas of unfairness, which may be corrected simply by the use of micro-balloon putty, a small amount of fiberglass cloth or mat, or some similar method. These alterations are acceptable if they are confined to covering up the metal hull or the metal keel for no more than 6 in (152.4 mm) above and/or below the bottom of the hull. Where an anti-corrosion mat has been placed between the keel and the hull, the thickness of that mat may be added to the 6 inch allowance.

Note that the purpose of this fairing is to permit a smooth transition from hull to keel; these methods may not be used to build a shape which is otherwise prohibited in these rules, particularly regarding hollows in the keel. If, in the process of fairing the keel into the hull as described in this section, it happens that a small hollow is created by the fairing, which stops at the 6 in (152.4 mm) height defined in the preceding paragraph, that hollow is allowed, provided that it is clearly incidental to the fairing, and is not part of an attempt to circumvent the hollow transverse section provision stated above. Also note that this 6 in (152.4 mm) band is the same band defined in the section on keels above.

PATENTED, COPYRIGHTED, & OTHERWISE PROTECTED DESIGNS & DESIGN CONCEPTS

No patented, copyrighted or otherwise legally protected design or design concept may be used in the design of a boat built to this measurement rule unless that design or design concept is available to all boats built to this measurement rule without charge.

MINIMUM CONSTRUCTION REQUIREMENTS

Scope & Proper Interpretation of these Scantlings

The construction minimum scantlings which follow are not intended to be a complete listing of all the components of construction of the boat, **nor does compliance with them ensure a strong or well-built boat**. Many critical items, such as rudder post, chain plates, and keel bolts, are not covered at all. These scantlings are meant to be a listing of a sufficient number of large or heavy structural items so that boats which comply with these scantlings will have, relative to their exact size and shape, weights, centers of gravity, and gyradii which are consistent from boat to boat. In other words, the goal of these scantlings is not to state all the requirements for a properly built M-Boat, but rather to define minimums for a sufficient number of structural components that it can be reasonably assumed that construction weights and weight locations will not substantially favor one boat over another with regard to racing performance.

In all cases, it remains the responsibility of the Designer and the Builder to ensure that the boat is a properly built and seaworthy boat.

Any item not specified in the following construction scantlings should be built in accord to best practices, as defined (for instance) in RINA, Lloyd's Rules for Aluminium Yachts, in American Bureau of Shipping's Rules for Offshore Yachts (ABS Rules), or with the methods and scantlings laid down in *The Elements of Boat Strength* by Dave Gerr.

Types of Materials and Methods of Construction

These minimum scantlings presume an aluminum boat, of welded construction, except that some deck and cabin areas may be riveted if specifically permitted in the scantlings. Where no construction method is specifically indicated, the construction is to be MIG or TIG welded, whichever is industry standard for that particular location and application.

While no one alloy of aluminum is specified for these scantlings, since they are minimums allowed for race performance purposes rather than for structural strength purposes, the following scantlings presume that the alloys used are 5383, 5456, or Hoogoven's Alustar.

The construction system envisions frames, floors and beams that are made together of one piece, or – where too large to be cut from one piece – of sections welded together, rather than from separate floor, frame and beam shapes. Throughout this section, it is assumed that doubling plates are used to ensure sufficient strength of any structural member which must be welded up from multiple pieces. Doubling plates are not to be counted as part of the compliance with the scantling; rather their weight is extra, above and beyond what the part would weigh if it were made all of one piece.

Note: If in any place there is minor discrepancy between dimensions listed on the drawing, versus maximums or minimums in the scantling text, the value in the text shall govern. The construction drawings are to be considered advisory illustrations, not necessarily exact rule values.

Scantling Review

These scantlings have been reviewed by an Independent Consultant who is very familiar with the ISO Standard, and have been found to comply with the ISO Standard for Category 5 yachts in every parameter evaluated.

MINIMUM CONSTRUCTION REQUIREMENTS for the ENGLISH SYSTEM

STRUCTURAL ITEM	MINIMUM SCANTLING
Frame Spacing	Frame spacing shall be not greater than 1' 5 1/2", except that one frame space may be one standard frame thickness greater for the purpose of making proper frame bevels. While it is not a requirement that a frame be located at the forward ending of the LWL, that assumption is made for defining frame scantlings. Where Frame 10 is not the forward ending of the LWL, it is assumed that references to Frame 10 are to the first frame forward of the forward ending of the LWL, and that references to all other frames are adjusted accordingly.
Vertical Keel	8" high x 1" thick. There shall be no lightening holes in the vertical keel.
Vertical Keel in Way of Mast	Not less than 1' 3 3/4" x 1" for at least 2 frames forward and 2 frames aft of center of mast step. The mast step is thus to be bounded on the fore and aft ends by a heavy frame at each end, with two standard and one heavy frame between these heavy end frames.
Stem	Height not less than 6 3/4" at connection to keel, tapering uniformly to 4 3/4" high over length of stem. 1" thick at keel to Frame 9; 7/8" thick forward of Frame 9. There shall be no lightening holes in the stem. The stem shall be fitted with a flange, 3" wide x 7/8" thick forward of Frame 9; 3" wide by 1" thick aft of Frame 9; 3" wide x 1 1/2" thick aft of Frame 17. Flange 3" width by 1 1/2" thick aft of Frame 17, 1" thick aft of Frame 9, and 7/8" thick forward of Frame 9.
Counter	Height not less than 6 3/4" at aft end of LWL, tapering uniformly to 5" at aft-most frame; 7/8" thickness throughout. There shall be no lightening holes in the counter.
Floors	Thickness same as frames; depth 1.6 x rule (not actual) keel vertical height at that fore / aft location. Where the counter sections are flat or have little deadrise, floors on the counter may be the same height as the vertical counter. Extra floors, at 1/2 the regular frame spacing, are to be fitted throughout the length of the mast step, and under any heavy machinery such as engines or generators. Along the length of the mast step, floors are to be at least the height of the vertical keel at that location. Flanges for floors are to be not less than 1/2" thick x 2 5/8" wide.
Standard Frames	Not less than 3/8" thick throughout. Height at floor not less than 3 9/16", tapered uniformly to 3 1/16" at the midpoint, and to 2 1/2" at the sheer line. All frames shall comply with the standard frame scantlings except for the heavy frames specified just below, and the frames in the area of the mast step and chain plates. Standard frames may have lightening holes as indicated on the accompanying drawing, one in each frame segment between longitudinal stiffeners, but all such lightening holes shall be essentially round, and shall occupy not more than 45% of the frame height at that point, exclusive of shell plating and frame flange. Minimum frame/floor radius for standard frames is 0' 8 7/8". Standard frames are to have flanges not less than 1/2" x 2 5/8".
Heavy Frames	Frames 12, 17, 22, 33, and 41 shall be heavy frames. Heavy frames and their associated floors and beams are to be of 1/2" aluminum plate throughout, and are to have a height not less than 5 3/4", with no taper. Heavy frames may have lightening holes as indicated on the accompanying drawing, but such holes shall be not more than one per longitudinal space, and shall not take up more than 45% of the frame height at that location, not counting shell plate and frame flange. Lightening holes shall be essentially round. Minimum frame / floor radius for heavy frames is 1' 11". Heavy frames are to have flanges not less than 1/2" x 2 3/4".
Frames at Chain Plates	Frames 24, 25 and 26 shall be 1/2" aluminum. Frames 24 and 26 shall have the same web and flange scantlings for floor, frame, and deck beam as heavy frames. Scantlings for frames 24, 25, and 26 shall be adjusted as indicated on the attached scantling drawing, as needed for adequate chain plate strength and support. Frames at chain plates shall not be tapered.

Longitudinal Hull Stiffeners	Longitudinal hull stiffeners shall be employed as indicated in the accompanying scantling drawing. There shall be a minimum of 8 stiffeners along the bottom and middle shell plating areas, and a minimum of 2 additional stiffeners along the top side portion of the shell plating. Bottom and middle plating stiffeners shall be not less than 3/8" thick x 1 1/4" high. Top side plating stiffeners shall be not less than 5/16" thick x 1 1/8" high. The lowest stiffener shall begin at a height approximately 0.4 ft. above the LWL; each succeeding stiffener shall begin an additional 0.4 ft. above the LWL, as indicated in the accompanying diagram. Each stiffener shall continue the full length of the hull, taken at the height above the LWL at which it begins and ends, except that a stiffener may be cut short if it interferes with the rudder post or some other structure at or near the aft end of the LWL. Stiffeners shall be angled such that they have no sharp twists in them, and positioned such that they divide the midship section into roughly equal parts, except that the upper-most top side stiffener may be positioned such that there is a larger than average space between it and the deck than between the other stiffeners. No lightening holes are permitted in longitudinal stiffeners.
Standard Beams	2 3/8" x 3/8" thick throughout, except on heavy frames. Beams are not to be tapered. Lightening holes are permitted, one per longitudinal space. Lightening holes must not take up more than 45% of the beam height at that location. For standard beams, the minimum beam / frame radius is 0' 6", except as indicated on the scantling drawing. Flanges are to be the same dimensions as flanges for the corresponding frame.
Heavy Beams	5 3/4" x 1/2". Minimum frame/beam radius is 1' 3 5/8". Beams are not to be tapered. Lightening holes are permitted one per longitudinal space. Lightening holes must not take up more than 45% of the beam height at that location. Flanges are to be the same dimensions as flanges for the corresponding frame.
Longitudinal Deck Stiffeners	Shall begin 0' 10" to either side of the centerline of the deck, and spaced 0' 10" apart thereafter. Deck longitudinal stiffeners run parallel to the centerline of the boat. Deck longitudinal stiffeners are 1 1/8" by 1/4". Generally, longitudinal stiffeners are continuous, except that: 1) they do not span hatches or small deck houses with planform area less than 30 ft ² ; 2) they do not pass through the partners at the mast; 3) they need not extend further forward than frame 4; 4) they are not required to extend all the way to the edge of the boat, but instead may stop at the nearest deck beam. No lightening holes are permitted in longitudinal stiffeners.
Longitudinal Heavy Deck Beams	Heavy longitudinals are to be fitted such that the foredeck centerline is reinforced against bending. This longitudinal reinforcement is to be carried aft as far as the point of attachment of the aft-most running backstay, and should be split into two pieces, one on each side of the boat, beginning at a point somewhere forward of the mast. Aft of the point of division into two pieces, each piece shall have at least these scantlings: 4" x 3/4" with flange 3" by 3/4". Forward of Frame 4, the longitudinal heavy deck beam shall have the same scantlings as the stem forward of Frame 3, so that the stem is in effect carried around the forward part of the boat and back down the deck to form one rigid vertical construction element. From Frame 4 aft to the point of division into two pieces, the minimum scantling shall be 4" x 3/4" with 3" x 3/4" flange.
Horizontal Plate Keel	There shall be a horizontal plate keel which constitutes the lower limit of the hull, at a height which provides a good foundation for mounting of the ballast keel. The plate keel shall be not less than 1 1/2" (38 mm) thick.
Main Hull Plating	The main hull plating shall continue from an upper limit to a lower limit defined as follows: <i>upper limit</i> – 1' 1" above the LWL, from stern to midship, and gradually increasing in height forward of midship to a maximum height of 2' 8 1/2" at the stem; <i>lower limit</i> – 4' 4 1/2" below, and parallel to, the LWL. The main hull plating shall be 3/8" thick (9.5 mm).

Bottom Hull Plating	The bottom hull plating shall extend from the lower limit of the main hull plating to the plate keel, and shall be 1/2" thick (13mm).
Topsides Hull Plating	The topsides plating shall extend from the upper limit of the main hull plating to the sheerline. If the topside plating is extended upward above the deck to form a bulwark-like rail, then the extension shall be of the same scantling as the topside plating. The topside plating shall be 5/16" thick (8mm).
Deck Plating	The basic deck plating shall be 1/4" thick (6.4 mm). This material is used for: 1) a belt running all around the deck, at least 8 1/2" wide, measured perpendicular to the edge of the boat; 2) a strip of 1/4" thick plating shall run down the centerline of the boat from the stem head to the forward end of the deck opening for the mast; 3) the entire deck shall be 1/4" thick forward of Frame 5, and aft of Frame 22 to Frame 34; 4) the entirety of the area occupied by the main cockpit. Areas not included in this listing may be reduced to 3/16" thick (4.75 mm) deck plating. While the hull is to be welded, the connection of 3/16" deck plating to 1/4" deck plating may be done by means of riveting.
Deck House Beams	Shall be the same scantlings as Standard Beams.
Deck House Longitudinals	Shall be the same scantlings as Longitudinal Deck Stiffeners.
Cockpit Frames & Beams	Shall be the same scantlings as Standard (deck) Beams.
Cockpit Longitudinals	Shall be the same scantlings as Longitudinal Deck Stiffeners.
Deck House Plating	Deck house side, forward, aft and top plating shall be not less than 3/16" (4.75 mm). Deck Houses may be of welded or riveted construction.
Cockpit Sides & Sole Plating	Shall be not less than 1/4" (6.4 mm).
Transom	The transom shall be not less than 3/8" (9.5 mm) thick plating.
Transom Frames & Longitudinals	Transom Frames shall have Standard Frame scantlings. Transom Longitudinals shall have the same scantlings as topside hull longitudinals.
Bulkhead at or Forward of point 6% of LWL Aft of Forward End of LWL	Any method of construction is acceptable but the weight must be not less than 1.375 lb / ft ² , and the bulkhead must be permanently fixed in place, though an opening may be provided for access forward, but the access must have a closure of weight equal to that of the bulkhead, and the closure must be in place and closed when the boat is racing.

Note that heavy frames may be moved forward or aft 1 frame space if indicated by the structural requirements of rig or keel, or if indicated by the requirements of the interior arrangement plan.

Minimum Weight of Rudder Stock

The rudder stock, excluding any attachments, for a rudder mounted at the aft end of LWL, shall weigh not less than 100 pounds (45.3 kg).

A trim tab or rudder mounted on the trailing edge of the main ballast keel does not count as a rudder for purposes of this section of the rule.

INTERIOR ARRANGEMENT AND RELATED REQUIREMENTS

Deck Houses

At least one deck house shall be fitted, the dimensions of which shall be not less than:

- Height of side above sheer line at mid-length of deck house: 1' 7" (482 mm)
- Height of center above sheer line at mid-length of deck house: 1' 8" (508 mm)
- Horizontal fore / aft length of deck house: 9' 3" (2.819 m)
- Horizontal athwartship width of deck house: 7' 4" (2.235 m)

The planform of the deck house shall be a rectangle with vertical or essentially vertical sides and forward and aft endings, or shall be a shape and size capable of containing an unaltered rectangle of the same or larger dimensions. Cut-outs in the deck house sides or front / back are permitted provided that the total frontal or side 2-dimensional areas are maintained.

Interior Arrangements

Interior arrangement shall include at least the following items:

- at least 8 built-in berths (not pipe berths); Note: swing-up (hinged) beds are built-in berths, provided that they include a frame of wood or metal, and utilize some sort of mattress, not a suspended cloth.
- at least 3 fully-enclosed heads, including w.c. and sink; at least one of such enclosed system must be entirely forward of the mast.
- cooking and eating facilities including at least the following:
 - cooking appliance or appliances, which taken together provide both oven and burner capability, whether or not those are in the same appliance or in the same location;
 - refrigerator(s) and freezer(s) adequate for a 4-day trip with 8 people;
 - canned goods storage sufficient for a 4-day trip for 8 people;
 - galley sink, not less than 165 in²;
 - microwave oven;
 - seating for at least 4 persons at one time;
- private owner's cabin, including berths and seating arrangements suitable for relaxed short cruises;
- navigation station including chart table, fixed chair and appropriate chart storage; or folding or fixed table(s) suitable for use of a laptop computer for reading charts, and provision for sitting while using that laptop computer.
- hanging lockers sufficient for 8 persons for a 4-day trip.

All of the preceding equipment is to be "off the shelf" equipment, unless there is a compelling reason for a custom-made piece of equipment. In that case, the owner or builder or manufacturer must show that there is no advantage in weight saving to using the custom-made piece of equipment.

DECK LAYOUT AND RELATED REQUIREMENTS

Cockpits & Cockpit Areas

The boat shall have at least two cockpits, which shall be fully self-draining, and separate from each other. One shall be the main working cockpit; the other, aft of the main working cockpit, shall be a cockpit dedicated to on-board, non-sailing guests.

The planform areas of these cockpits shall be not greater than:

- Main Working Cockpit(s) total: 57.0 ft² (5.30 m²)
- Guest Cockpit: 15 ft² (1.394 m²)

The main working cockpit may be comprised of two or more physical cockpits, each of which is used for steering the boat and/or trimming sails and other similar activities. Where there are more than one working cockpit, their total planform area shall be not greater than that allowed in this section.

Additional arrangements may be provided for on-deck sail storage, etc, but where these are actual openings in the deck, they must be self-draining or fully enclosed and provided with a pump system, and must be closed by a cover of equal weight and vertical strength (for standing on) as the deck area that they replace. The cover shall be closed when these areas are not in use, and no person shall stand, sit or kneel in these areas for any purpose except storage / retrieval of sails into or from the storage area.

To avoid the use of excessive numbers or sizes of hatches to save weight, hinged hatch covers shall maintain the same structural scantlings as, or greater than, the piece of deck or deckhouse which they replace..

PROVISIONAL ENGINE AND PROPELLER REQUIREMENTS

Engine Requirements

The boat shall be equipped with a diesel engine which, in combination with the propeller and propeller mounting utilized, shall be demonstrably capable of driving the boat in the forward direction at a speed of at least 9.0 knots, sustainable for at least one nautical mile, in smooth water with no wind. The transmission used shall be capable of powering the boat in reverse.

The engine shall not be mounted in, or immediately adjacent to, the owner's cabin.

Propeller and Propeller Mounting Requirements

While the value of PIPA, as standardly defined (see Appendix 2), is not a direct component of the rating, each boat shall have a propeller and mounting which has a PIPA value of not less than 0.0117, and which meets the following additional requirements:

- the propeller used shall be a 3- or 4-blade feathering propeller;
- the propeller mounting shall meet all the requirements in Appendix 2 for an “out of aperture” propeller mount;
- ESL shall not exceed 5.25 ft (1.6 m).

CREW LIMIT

Crew & Observer Limits

The maximum number of crew on board during a race, not counting guest observers, shall be 19.

The maximum number of guest observers on board during a race shall be 2. While observers may make occasional suggestions or comments, they are not to be regular tacticians, navigators, or strategists during a race, and – except in a clear emergency (where immediate action is needed to avoid injury to a person or to avoid severe damage to the boat or its equipment) – they shall play no physical role in sailing the boat during a race.

Provisional Formulas for Boats Measured Under the Metric System

METRIC MEASUREMENT CERTIFICATES VALIDITY AND RESOLUTION IN CASE OF CONFLICT

The following Metric formulas and scantlings are provided for the use of those wishing to work under the Metric system of measurement. Rating Certificates developed under the Metric system are valid for all purposes. However, in case of question or conflict, the English units and their calculated results shall govern.

CLASS RATING

The Class Rating shall be 14.021 meters.

BASIC RATING FORMULA

The basic rating formula for the Universal Rule of Measurement is:

$$R = 0.18 \frac{L \sqrt{S}}{\sqrt[3]{D}}$$

Where:

- R = Class Rating in Meters;
- L = Rated Length in Meters;
- S = Rated Sail Area in Square Meters;
- D = Rated Displacement in Cubic Meters.

LENGTH FORMULAS

The formulas for determining Rated Length are:

$$L = LWL + P_{qbl} + P_{fwd} + P_{aft} + P_{disp} + P_{beam} + P_{draft} + P_{fbd} \quad (2)$$

Where:

- L = Rated Length In Meters;
- LWL = Water Line Length in Meters, in Measurement Trim
- P_{qbl} = Quarter Beam Penalty in Meters;
- P_{fwd} = Excessive Breadth of Section Penalty at Forward End of LWL in Meters;
- P_{aft} = Excessive Breadth of Section Penalty at Aft End of LWL in Meters;
- P_{disp} = Insufficient Actual Displacement Penalty in Meters;
- P_{beam} = Excessive or Insufficient Breadth Penalty at Maximum Beam Station in Meters;
- P_{draft} = Excessive Draft at the Maximum Draft Station in Meters;
- P_{fbd} = Insufficient freeboard penalty in Meters.

Maximum and Minimum LWL

The Maximum LWL in Measurement Trim shall be:

$$LWL_{\max} = (1.08 * \text{Class Rating}) + 1.524 \text{ meters.} \quad (3)$$

The Minimum LWL in Measurement Trim shall be:

$$LWL_{\min} = (1.08 * \text{Class Rating}) + 0.914 \text{ meters.} \quad (4)$$

Quarter Beam Length

The maximum quarter beam length, in meters, without penalty shall be:

$$QBL_{\max} = \frac{100 - \sqrt{\frac{LWL}{0.3048}}}{100} * LWL + 0.73152 \quad (5)$$

If the quarter beam length is greater than the maximum permitted without penalty in (5), the quarter beam penalty shall be given by:

$$P_{qbl} = 0.5 \left[QBL - \frac{100 - \sqrt{\frac{LWL}{0.3048}}}{100} * LWL \right] - 0.36576 \quad (6)$$

Forward Breadth

The maximum forward breadth, taken at a height of 122 mm above LWL, without penalty shall be:

$$FWD_{\max} = 0.04 * LWL \quad (7)$$

If the forward breadth as defined above is greater than the maximum allowed without penalty in (7), the penalty shall be given by:

$$P_{fwd} = 2 * (\text{actual forward breadth} - (0.04 * LWL)) \quad (8)$$

Aft Breadth

The maximum aft breadth, taken at a height of 122 mm above LWL, without penalty shall be:

$$AFT_{\max} = 0.12 * LWL \quad (9)$$

If the aft breadth as defined above is greater than the maximum allowed without penalty in (9), the penalty shall be given by:

$$P_{aft} = \text{actual aft breadth} - (0.12 * LWL) \quad (10)$$

Displacement

The minimum displacement (in cubic meters) without penalty shall be

$$\text{Disp}_{\min} = (0.2 * \text{LWL} + (0.5 * 0.3048))^3 \quad (11)$$

If the actual displacement (in cubic meters) is less than the minimum given by (11), then the displacement penalty shall be

$$P_{\text{disp}} = \text{LWL} - \frac{\sqrt[3]{(\text{actual displacement})} - (0.5 * 0.3048)}{0.2} \quad (12)$$

Rated displacement, D , in the rating formula shall be the actual displacement of the boat as determined by weighing. D shall not be taken as greater than the rule minimum displacement as defined in (11) above. Therefore

$$\sqrt[3]{D} \leq (0.2 \text{ LWL} + (0.5 * 0.3048)) \quad (13)$$

Beam

The Beam, B , as defined above under Quarter Beam Length, shall be not less than

$$B_{\min} = 0.235 * \text{LWL} \quad (14)$$

If B is less than the minimum defined in (14), the penalty shall be

$$P_{\text{beam}} = 0.235 * \text{LWL} - \text{actual LWL beam} \quad (15)$$

The Beam, B , as defined above under Quarter Beam Length, shall be not greater than

$$B_{\max} = 0.25 * \text{LWL} \quad (16)$$

If B is greater than the maximum defined in (16), the penalty shall be

$$P_{\text{beam}} = \text{actual LWL beam} - (0.25 * \text{LWL}) \quad (17)$$

Draft

The maximum draft shall be

$$H_{\max} = 0.16 * \text{LWL} + 0.7803 \text{ m} \quad (18)$$

If the draft exceeds the maximum defined just above, the penalty shall be

$$P_{\text{draft}} = 3 * (\text{actual draft} - (0.16 * \text{LWL} + 0.7803)) \quad (19)$$

Freeboard

The freeboard taken in measurement trim at the midship (50% LWL) station shall be not less than

$$F_{\min} = 0.062 * \text{LWL} + 0.183 \text{ m} \quad (20)$$

The freeboard at the forward end of LWL, in measurement trim, shall be not less than

$$F_{\min \text{ fwd}} = F_{\min} * 1.179 \quad (21)$$

and the freeboard at the aft end of LWL, in measurement trim, shall be not less than

$$F_{\text{min aft}} = F_{\text{min}} * 0.979 \quad (22)$$

If any of the above 3 freeboard measurements is less than the minimum required, the penalty shall be

$$P_{\text{fbd}} = 2 * (F_{\text{rqd}} - F_{\text{act}}) \quad (23)$$

where:

F_{rqd} = Freeboard required at that station from (20), (21), or (22) above;

F_{act} = Actual freeboard at that station.

If more than one of the measured freeboards is less than the required minimum, the penalty shall be based on the largest deficiency, not the sum of the deficiencies.

SAIL AREA

Sail Area Formula

Rated sail area, S, in the rating formula shall be the triangular area of the mainsail plus 85% of the area of the fore triangle, that is

$$S = \frac{P * E}{2} + 0.85 \frac{I * J}{2} \quad (24)$$

Where:

P = Mainsail luff length in Meters;

E = Mainsail foot length in Meters;

I = Fore triangle height in Meters, taken from the sheer line abreast the mast;

J = Base of fore triangle in Meters.

Maximum Height of Sail Plan

The maximum height of the sail plan above the sheer line, measured along the aft edge of the mast (not necessarily vertical), shall be given by

$$\text{Rig Height}_{\text{max}} = 1.85 \sqrt{S} + 1.524 \quad (25)$$

Maximum Girth of Mainsail

The maximum dimension of the mainsail, measured perpendicular to the luff at a height 65% of P above the base of P, shall be

$$\text{Girth}_{\text{max}} = 0.56 * E \quad (26)$$

Maximum Depth of Rudder Below LWL

The maximum depth of the tip of the rudder below the LWL shall be not greater than

$$\text{Rudder Depth}_{\text{max}} = 0.425 * H_{\text{max}} \quad (27)$$

Where

H_{max} = maximum draft without penalty per (18)

Centerboards & Daggerboards

The maximum total exposed lateral area of centerboard(s) and/or daggerboard(s), if any, in meters², shall be not greater than

$$\text{Area}_{\text{max}} = 0.128 * \text{LWL} \quad (28)$$

The maximum draft of the boat with the centerboard(s) and/or daggerboard(s) fully extended shall not exceed

$$\text{Total Draft}_{\text{max}} = H_{\text{max}} * 1.43 \quad (29)$$

Where:

H_{max} = Maximum Draft without Penalty from (18) above.

Minimum Weight of Rudder Stock

The rudder stock, excluding any attachments, for a single rudder mounted at the aft end of LWL, shall weigh not less than 45.3 kg.

A trim tab or rudder mounted on the trailing edge of the main ballast keel does not count as a rudder for purposes of this section of the rule.

MINIMUM CONSTRUCTION REQUIREMENTS for the METRIC SYSTEM

STRUCTURAL ITEM	MINIMUM SCANTLING
Frame Spacing	Frame spacing shall be not greater than 444.5 mm, except that one frame space may be one standard frame thickness greater for the purpose of making proper frame bevels. While it is not a requirement that a frame be located at the forward ending of the LWL, that assumption is made for defining frame scantlings. Where Frame 10 is not the forward ending of the LWL, it is assumed that references to Frame 10 are to the first frame forward of the forward ending of the LWL, and that references to all other frames are adjusted accordingly.
Vertical Keel	200 mm high x 26 mm thick. There shall be no lightening holes in the vertical keel.
Vertical Keel in Way of Mast	Not less than 400 mm x 26 mm for at least 2 frames forward and 2 frames aft of center of mast step. The mast step is thus to be bounded on the fore and aft ends by a heavy frame at each end, with two standard and one heavy frame between these heavy end frames.
Stem	Height not less than 171 mm at connection to keel, tapering uniformly to 121 mm high over length of stem. 26 mm thick at keel to Frame 9; 22 mm thick forward of Frame 9. There shall be no lightening holes in the stem. The stem shall be fitted with a flange, 76 mm wide x 22 mm thick forward of Frame 9; 76 mm wide by 26 mm thick aft of Frame 9; 76 mm wide x 38 mm thick aft of Frame 17. Flange 76 mm width by 38 mm thick aft of Frame 17, 25.4 mm thick aft of Frame 9, and 22.25 mm thick forward of Frame 9.
Counter	Height not less than 171 mm at aft end of LWL, tapering uniformly to 127 mm at aft-most frame; 22 mm thickness throughout. There shall be no lightening holes in the counter.
Floors	Thickness same as frames; depth 1.6 x rule (not actual) keel vertical height at that fore / aft location. Where the counter sections are flat or have little deadrise, floors on the counter may be the same height as the vertical counter. Extra floors, at ½ the regular frame spacing, are to be fitted throughout the length of the mast step, and under any heavy machinery such as engines or generators. Along the length of the mast step, floors are to be at least the height of the vertical keel at that location. Flanges for floors are to be not less than 12.7 mm thick x 66.7 mm wide.
Standard Frames	Not less than 9.5 mm (3/8") thick throughout. Height at floor not less than 90 mm, tapered uniformly to 78 mm at the midpoint, and to 64 mm at the sheer line. All frames shall comply with the standard frame scantlings except for the heavy frames specified just below, and the frames in the area of the mast step and chain plates. Standard frames may have lightening holes as indicated on the accompanying drawing, one in each frame segment between longitudinal stiffeners, but all such lightening holes shall be essentially round, and shall occupy not more than 45% of the frame height at that point, exclusive of shell plating and frame flange. Minimum frame/floor radius for standard frames is 225 mm. Standard frames are to have flanges not less than 12.7 mm x 66.7 mm.
Heavy Frames	Frames 12, 17, 22, 33, and 41 shall be heavy frames. Heavy frames and their associated floors and beams are to be of 13 mm (1/2") aluminum plate throughout, and are to have a height not less than 146 mm, with no taper. Heavy frames may have lightening holes as indicated on the accompanying drawing, but such holes shall be not more than one per longitudinal space, and shall not take up more than 45% of the frame height at that location, not counting shell plate and frame flange. Lightening holes shall be essentially round. Minimum frame / floor radius for heavy frames is 584 mm. Heavy frames are to have flanges not less than 12.7 mm x 69.9 mm.

Frames at Chain Plates	Frames 24, 25 and 26 shall be 13 mm (1/2") aluminum. Frames 24 and 26 shall have the same web and flange scantlings for floor, frame, and deck beam as heavy frames. Scantlings for frames 24, 25, and 26 shall be adjusted as indicated on the attached scantling drawing, as needed for adequate chain plate strength and support. Frames at chain plates shall not be tapered.
Longitudinal Hull Stiffeners	Longitudinal hull stiffeners shall be employed as indicated in the accompanying scantling drawing. There shall be a minimum of 8 stiffeners along the bottom and middle shell plating areas, and a minimum of 2 additional stiffeners along the top side portion of the shell plating. Bottom and middle plating stiffeners shall be not less than 9.5 mm (3/8") thick x 32 mm high. Top side plating stiffeners shall be not less than 8 mm (5/16") thick x 29 mm high. The lowest stiffener shall begin at a height approximately 122 mm above the LWL; each succeeding stiffener shall begin an additional 122 mm above the LWL, as indicated in the accompanying diagram. Each stiffener shall continue the full length of the hull, taken at the height above the LWL at which it begins and ends, except that a stiffener may be cut short if it interferes with the rudder post or some other structure at or near the aft end of the LWL. Stiffeners shall be angled such that they have no sharp twists in them, and positioned such that they divide the midship section into roughly equal parts, except that the upper-most top side stiffener may be positioned such that there is a larger than average space between it and the deck than between the other stiffeners. No lightening holes are permitted in longitudinal stiffeners.
Standard Beams	60 mm x 9.5 mm (3/8") thick throughout, except on heavy frames. Beams are not to be tapered. Lightening holes are permitted, one per longitudinal space. Lightening holes must not take up more than 45% of the beam height at that location. For standard beams, the minimum beam / frame radius is 152 mm, except as indicated on the scantling drawing. Flanges are to be the same dimensions as flanges for the corresponding frame.
Heavy Beams	146 mm x 13 mm (1/2"). Minimum frame/beam radius is 397 mm. Beams are not to be tapered. Lightening holes are permitted one per longitudinal space. Lightening holes must not take up more than 45% of the beam height at that location. Flanges are to be the same dimensions as flanges for the corresponding frame.
Longitudinal Deck Stiffeners	Shall begin 254 mm to either side of the centerline of the deck, and spaced 254 mm apart thereafter. Deck longitudinal stiffeners run parallel to the centerline of the boat. Deck longitudinal stiffeners are 29 mm by 6 mm (1/4"). Generally, longitudinal stiffeners are continuous, except that: 1) they do not span hatches or small deck houses with planform area less than 2.79 m ² ; 2) they do not pass through the partners at the mast; 3) they need not extend further forward than frame 4; 4) they are not required to extend all the way to the edge of the boat, but instead may stop at the nearest deck beam. No lightening holes are permitted in longitudinal stiffeners.
Longitudinal Heavy Deck Beams	Heavy longitudinals are to be fitted such that the foredeck centerline is reinforced against bending. This longitudinal reinforcement is to be carried aft as far as the point of attachment of the aft-most running backstay, and should be split into two pieces, one on each side of the boat, beginning at a point somewhere forward of the mast. Aft of the point of division into two pieces, each piece shall have at least these scantlings: 102 mm x 19 mm with flange 76 mm by 19 mm. Forward of Frame 4, the longitudinal heavy deck beam shall have the same scantlings as the stem forward of Frame 3, so that the stem is in effect carried around the forward part of the boat and back down the deck to form one rigid vertical construction element. From Frame 4 aft to the point of division into two pieces, the minimum scantling shall be 102 mm x 19 mm with 76 mm x 19 mm flange.
Horizontal Plate Keel	There shall be a horizontal plate keel which constitutes the lower limit of the hull, at a height which provides a good foundation for mounting of the ballast keel. The plate keel shall be not less than 38 mm (1 1/2") thick.

Main Hull Plating	The main hull plating shall continue from an upper limit to a lower limit defined as follows: <i>upper limit</i> – 330 mm above the LWL, from stern to midship, and gradually increasing in height forward of midship to a maximum height of 826 mm at the stem; <i>lower limit</i> – 1.334 m below, and parallel to, the LWL. The main hull plating shall be 3/8" thick (9.5mm).
Bottom Hull Plating	The bottom hull plating shall extend from the lower limit of the main hull plating to the plate keel, and shall be 13 mm (1/2") thick.
Topsides Hull Plating	The topsides plating shall extend from the upper limit of the main hull plating to the sheerline. If the topside plating is extended upward above the deck to form a bulwark-like rail, then the extension shall be of the same scantling as the topside plating. The topside plating shall be 8 mm (5/16") thick.
Deck Plating	The basic deck plating shall be 6.4 mm (1/4") thick . This material is used for: 1) a belt running all around the deck, at least 216 mm wide, measured perpendicular to the edge of the boat; 2) a strip of 6.4 mm thick plating shall run down the centerline of the boat from the stem head to the forward end of the deck opening for the mast; 3) the entire deck shall be 6.4 mm thick forward of Frame 5, and aft of Frame 22 to Frame 34; 4) the entirety of the area occupied by the main cockpit. Areas not included in this listing may be reduced to 4.75 mm (3/16") thick deck plating. While the hull is to be welded, the connection of 4.75 mm deck plating to 6.4 mm deck plating may be done by means of riveting.
Deck House Beams	Shall be the same scantlings as Standard Beams.
Deck House Longitudinals	Shall be the same scantlings as Longitudinal Deck Stiffeners.
Cockpit Frames & Beams	Shall be the same scantlings as Standard (deck) Beams.
Cockpit Longitudinals	Shall be the same scantlings as Longitudinal Deck Stiffeners.
Deck House Plating	Deck house side, forward, aft and top plating shall be not less than 4.75 mm (3/16"). Deck Houses may be of welded or riveted construction.
Cockpit Sides & Sole Plating	Shall be not less than 6.4 mm (1/4").
Transom	The transom shall be not less than 9.5 mm (3/8") thick plating.
Transom Frames & Longitudinals	Transom Frames shall have Standard Frame scantlings. Transom Longitudinals shall have the same scantlings as topside hull longitudinal.
Bulkhead at or Forward of point 6% of LWL Aft of Forward End of LWL	Any method of construction is acceptable but the weight must be not less than 6.71 kg/m ² , and the bulkhead must be permanently fixed in place, though an opening may be provided for access forward, but the access must have a closure of weight equal to that of the bulkhead, and the closure must be in place and closed when the boat is racing.

Note that heavy frames may be moved forward or aft 1 frame space if indicated by the structural requirements of rig or keel, or if indicated by the requirements of the interior arrangement plan.

FRAME 32

MIDSHIP CONSTRUCTION SECTION

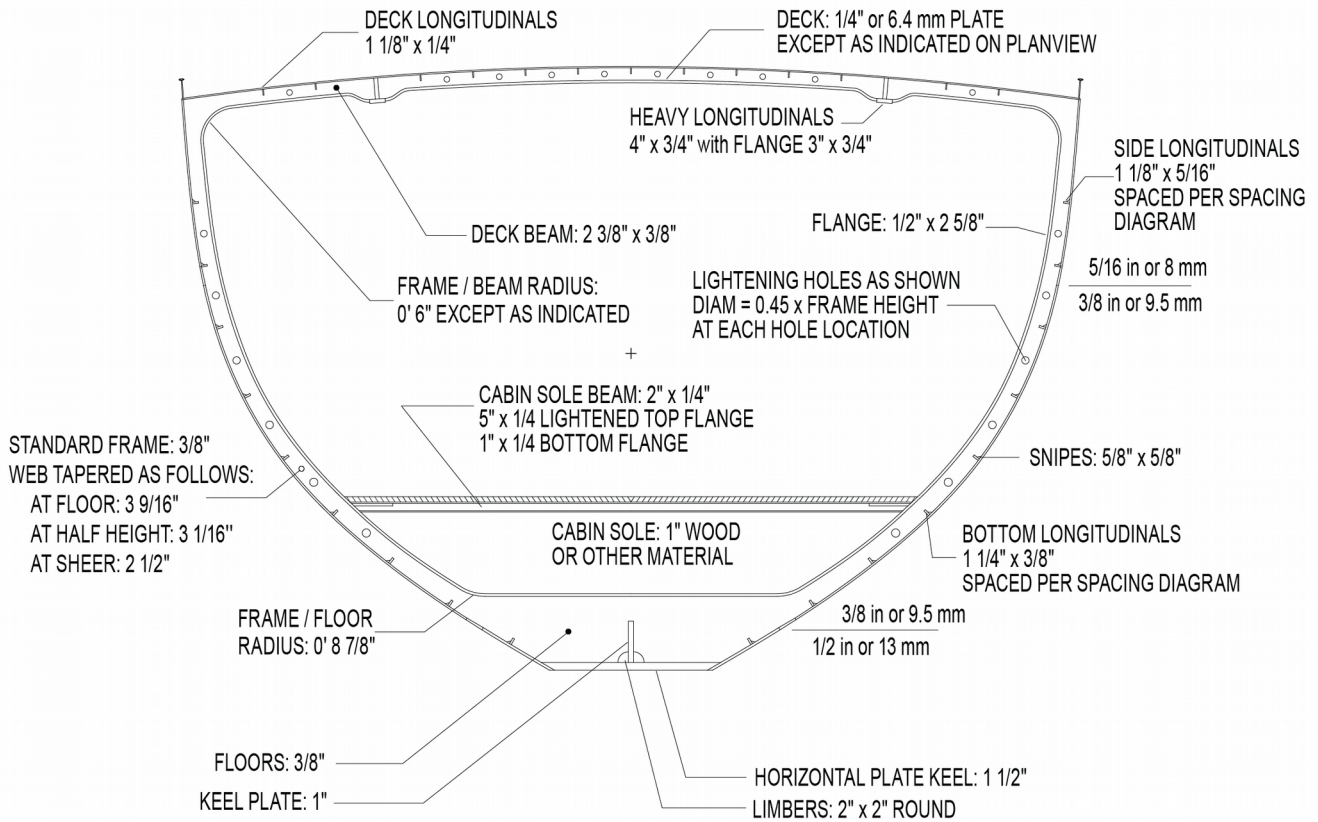

DO NOT SCALE

CORRESPONDS TO:	
	LINES PLAN DWG 349
©2011, 2014	SAIL PLAN DWG 355
David J. Fladlien	LAYOUT & ARRANGEMENT PLAN DWG 354

©2016 FLADLIEN & ASSOCIATES, LLC.
TERMS OF USE: <http://mclassyachts.com/terms.html>

CONSTRUCTION SCANTLINGS	CLASS M SLOOP FOR MEASUREMENT RULE
	HULL 66F2 - DJF
FLADLIEN & ASSOCIATES, LLC	DWG No. 768 Rev 6 - DJF
	SCALE: FULL
	OCTOBER 22, 2015 M ▲ F

APPENDIX 1

General Discussion of Permissible Hull Shapes Under This Measurement Rule

The objective of this measurement rule is to produce a modernized version of the traditional M-Class, and is therefore a tightly-regulated development class. In doing so, the principle is that the boat which results should in a generalized way look, above the water in profile, like the last of the Universal Rule boats of the 1930s. This is not necessarily true of transverse sections, however, or even of the plan view, as those don't influence too greatly the impression left by the boat on the typical viewer. Hence, while the stem angle and counter angle are limited by the rule, the transverse sections may be "V" shaped, "U" shaped, or even round, flat, or square with a chine. This is true anywhere along the length of the boat. Similarly, the ends of the boat in plan view may be greatly "straightened" to make the corresponding sides more vertical.

However, the boat may not have protrusions from the hull. Those were never seen in the original M-Class, and so "humps" under the bow of the boat are not permitted, and neither are bulbs protruding forward of the waterline under water, even though in theory neither of these would affect the above-water appearance of the boat. However, it was common to have a hollow in the stem of the boat beginning slightly aft of the forward end of the waterline. This was most often in the R-Class, but was also seen in the J-Class *Rainbow* and (to some appearances) in *Endeavour* and *Endeavour II*. These hollows are legal in Class M, but see the Supplement for limits on the radius of such hollows.

It is desired to have a more modern boat, so that a separate rudder hung on a skeg at the aft end of the waterline is permitted, as is a greater-than-unity taper keel ("upside-down" keel) with or without winglets.

Clearly not all of the above-mentioned characteristics can be represented in one drawing, but this rule does contain a lines plan which gives a general idea of what we expect a modern M-Boat to look like. This is the Hull 66F2b whose lines plan is attached, and which should therefore serve as a good guide for characteristics which are permitted, but not for characteristics which are prohibited. In other words, if Hull 66F2b contains a particular trait, then that the trait is permitted; however, the fact that Hull 66F2b does not embody some other characteristic should not be taken as a statement that the trait in question is prohibited.

For the guidance of anyone designing a boat to this measurement rule, if a trait or feature is contained in Hull 66F2b, or is a *direct* extension of such a trait, or if the proposed trait is mentioned in this Appendix as being permitted, then that trait is permitted. If the trait is prohibited in this Appendix, or in the body of the rule itself (such as "humps" under the bow of the boat), then that trait is prohibited.

If a proposed trait is neither specifically permitted nor specifically prohibited, then the legality of the trait is questionable. The best keys to resolving that question are:

First: does the proposed trait continue the kind of appearance, performance and handling characteristics of the class as described above? If so, this is an argument for the trait's acceptability.

Second: does the proposed trait exist in any Universal Rule or International Rule boat in the 1920s, 1930s, 1940s, or 1950s? If it does exist, then this is a very strong case for the trait's acceptability.

Any designer should keep in mind, however, that anyone who contemplates building a boat to this measurement rule almost certainly wants a modernized, but still traditional, kind of boat. It is therefore assumed that the owners of these boats will have the authority to rule out any design concept which they collectively feel is contrary to the modernized traditional concept for this class as outline above, and as defined to some (definitely not all-inclusive) extent in the text of the rule. The designer should be prepared for the potential that a boat which clearly and significantly falls outside of these guidelines will not be permitted to race with the class, regardless of its compliance with the letter of the rule.

The order of precedence for evaluating legality of concepts is:

First: The text of this rule, including this Appendix, and the text of the Rule Supplement;

Second: Lines Plan of Hull 66F2b, included in this rule, as discussed in this appendix;

Third: Historical precedent as discussed in this appendix.

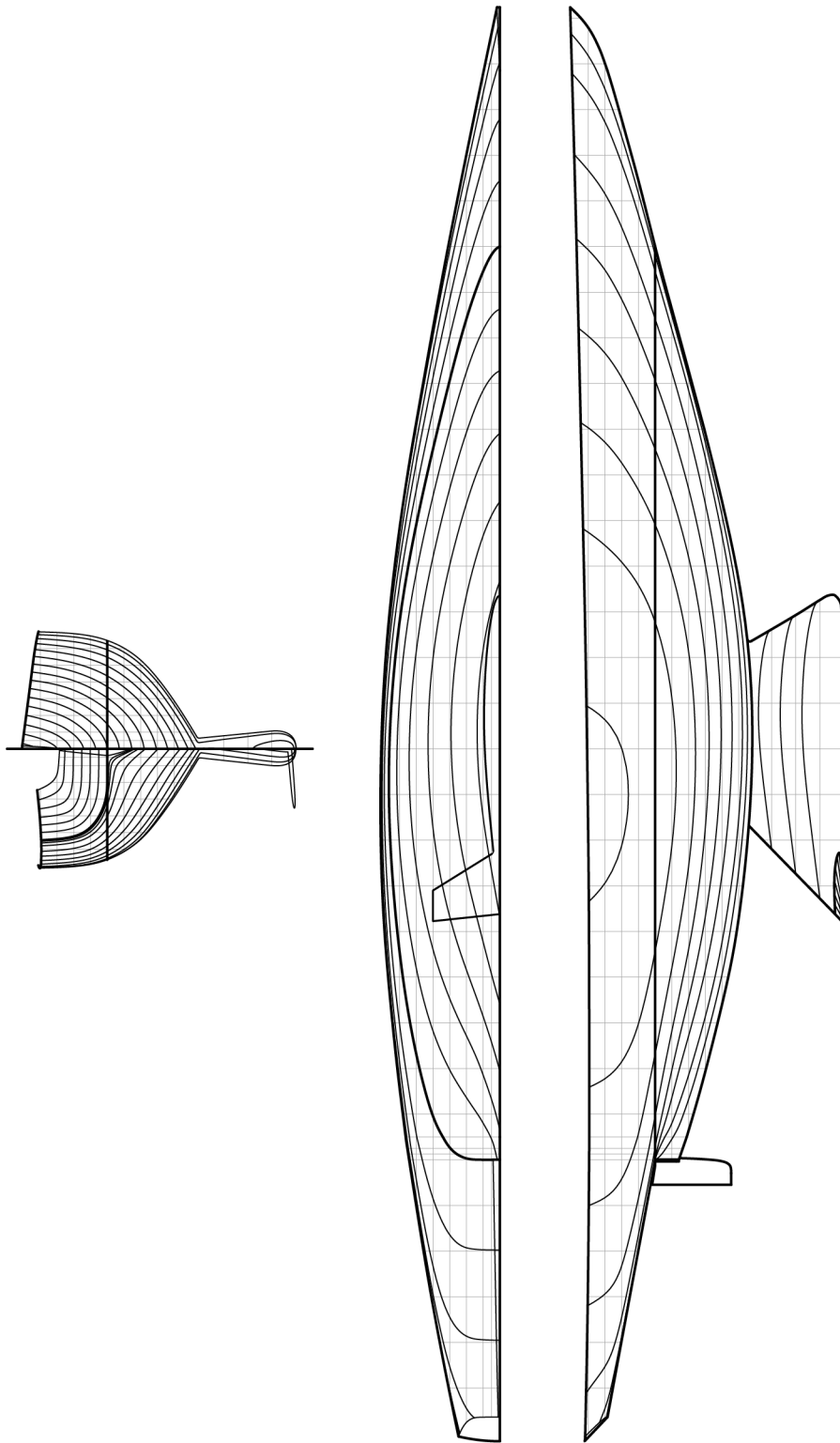

LINES PLAN	CLASS M SLOOP FOR SPECULATION
	HULL 66F2b-DJF
	DWG No. 605-DJF
	SCALE: FULL
	JULY 1, 2014
	M.A.F.



FLADJEN
& ASSOCIATES, LLC

©2016 FLADJEN & ASSOCIATES, LLC.
TERMS OF USE: <http://mclassyachts.com/terms.html>

APPENDIX 2

Out of Aperture Propeller Mounts

Calculation of PIPA – Parameters

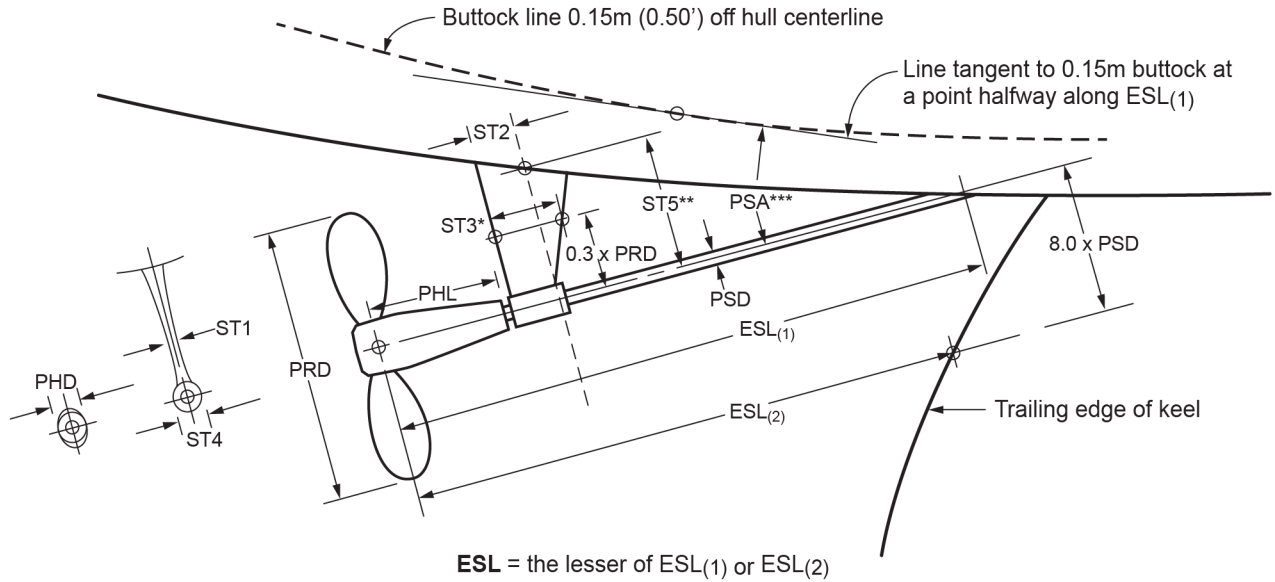

***ST3** is the maximum strut width measured parallel to the propeller shaft found not more than 0.3 x PRD above the shaft centerline.

****ST5** is measured perpendicular to the shaft centerline from the hull to the shaft centerline at the forward end of ST2.

*****PSA** (Propeller Shaft Angle) may be measured in two steps:
 1. Angle between shaft centerline and level datum line
 2. Angle between buttock tangent line and level datum line
 Add angles to arrive at PSA.

Calculation of PIPA – Formulas

$$IPA = (0.04 + \sin(PSA))^3 \times (PSD (ESL - ST 2 - PHL) + ST 4 (ST 2 + PHL)) + 0.03 \times ST 1 (ST 5 - ST 4/2)$$

$$PIPA = IPA + 0.70 \times (0.9 PHD)^2$$

APPENDIX 3

Special Rules for Exterior Decorum

Advertising

Except for a decal or similar emblem which may be placed on the boat during a specific regatta for a sponsor of that regatta, no advertising symbols may be displayed on the sides or transom of the boat, nor on the underbody, appendages or sails. Where a sponsor's mark of the kind permitted herein is displayed, it will have only one such mark on each side of the boat. Sponsors advertising in this manner must be sponsors of the entire event, or of the entire M-Class in that event, and not just of a particular boat or boats or team.

Advertising which complies with the requirements of the previous paragraph must further contain only words and/or logo clearly identifying the sponsor and/or his/her product. In no case shall there be any advertising containing any image which a reasonable person would deem lewd or marginal or debatable in that regard.

Sails may contain the standard maker's mark, of standard size, in the vicinity of the tack of the sail, or the clew if the sail is a symmetrical spinnaker.

Winches, spars, and fittings may contain standard manufacturer's marks of the standard size.

The designer(s) of the boat, and the builder(s) of the boat may place or cause to be placed an identifying plaque or engraving in a prominent place on a bulkhead below deck. As above, these marks or plaques are to be artful, or simple text, and serve only the purpose of identifying the designer(s) or builder(s), and shall not be done in a manner which a reasonable person would deem to be advertising.

Symbols on Hull or Transom

In principle, there should not be symbols or markings on the hull or the transom other than wording stating the name and (if desired) the home port of the boat. A single small symbol (not larger in any dimension than the boat name) and which has special significance to the owner would be acceptable.

By tradition, a stripe or arrow has long been permitted on the topside a short distance below the sheer line. An additional strip of a color which contrasts with both the side and bottom paint (that is, "boot top") has also been allowed at the connection of the bottom paint to the topside paint. This is particularly helpful when the construction or construction material of the boat dictates a bottom paint color which does not butt well with the desired topside color. These stripes, arrows, and boot tops are permitted providing that they are only large enough to be clearly visible and to accomplish their intended artistic purpose.

Placing of the boat's name on the side of the boat, on the bulwark or just below the deck line, is permitted, providing the name is in lettering not more than 7 in (178 mm) in height.

There are to be no pictures, artist's rendering of people or animals, or any other such displays on the topsides, underbody, appendages or transom of the boat, except that the home port of the boat may be displayed on the transom if the name of the boat is also displayed either on the transom or the side of the boat. In general, the paint on the topsides of the boat should be of one color only. Speckles or light marbling of the color might be permissible if approved by the governing body, but multi-color topsides are not permitted. Subtle color gradients are permitted.

APPENDIX 4**Major Design Parameter Limits List for English Units**

MESUREMENT PARAMETER	DESCRIPTION	LIMIT
LWL	Line of Flotation in Measurement Trim	$(1.08 * R + 3) \leq LWL \leq (1.08 * R + 5)$
QBL	Quarter Beam Length	Penalty if $> \frac{100 - \sqrt{LWL}}{100} * LWL + 3.34$
Forward end QBL	Forward end of QBL	Not to be taken as further aft than $0.12 * LWL$
BWL	Maximum Beam along LWL	See Limit on B just below
B	Equal to BWL as defined just above	$(0.235 * LWL) \leq B \leq (0.25 * LWL)$
FWD	Breadth at +0.400 ft WL at fwd end LWL	Penalty if $> (0.04 * LWL)$
AFT	Breadth at +0.400 ft WL at aft end LWL	Penalty if $> (0.14 * LWL)$
DISP	Displacement in Measurement Trim	Penalty if $< (0.2 * LWL + 0.5)^3$ in ft ³
Draft	Maximum depth of boat incl keel	Penalty if $> 0.16 * LWL + 2.56$
Fmin	Minimum Freeboard	Penalty if $<$ limits in (20), (21), or (22) page 11
Stem Angle	Angle of Stem to LWL at line of flotation	Penalty if < 12.90 degrees
Counter Angle	Angle of Counter to LWL at line of flotation	Penalty if < 9.75 degrees
Tumble home	amount per side by which deck is narrower than maximum beam at that vertical location	Penalty if > 0.32 ft
Rig Height	Height of upper P band above deck at side of boat opposite mast	maximum allowed = $1.85 \sqrt{S} + 5.0$
Mainsail Max Girth	maximum dimension perpendicular to luff of sail at height = $0.65 * P$	maximum allowed = $0.56 * E$
Headboard length	length of headboard at longest point	maximum allowed = 1.40 ft
Maximum Height of Fore Triangle	Maximum height of halyard sheave intersection above sheer line	maximum allowed = 82.5 ft
Max height of Spin Halyard	Max height of Spinnaker halyard above top of I dimension	maximum allowed = 0.5 ft
Max length of	maximum length of spinnaker pole from	max allowed = $1.10 * J$

spinnaker pole	inboard end to bearing point of guy	
min weight mast	minimum weight of mast in specified condition	minimum = 850 lbs
max mast motion	maximum fore/aft motion of mast at deck	maximum allowed = 0.333 ft
max boom width	maximum width of boom at any location	maximum allowed = 2.50 ft
max boom depth	maximum depth of boom at any location	maximum allowed = 1.375 ft
rudder aft of LWL	maximum distance leading edge of rudder or post can be aft of aft end of LWL	maximum allowed = 0.125 ft
Rudder Depth	maximum depth of rudder below LWL	maximum allowed = 0.5 * Maximum Draft
Maximum Keel Taper Ratio	maximum ration of keel tip chord / keel root chord	maximum allowed = 2.0
Centerboard / Daggerboard max depth	maximum draft of a boat below LWL with a centerboard or daggerboard fully extended	maximum allowed = 1.43 * Maximum Draft with centerboard or daggerboard not extended
Centerboard / Daggerboard max area	maximum exposed area of a centerboard or daggerboard with that board fully extended	maximum allowed = 0.42 * LWL (area in ft ²)
Maximum Weight of Keel material	heaviest material from which a keel may be made	maximum allowed = 708 lbs / ft ³
Maximum Chord Length of Trim Tabs	longest horizontal dimension of a trim tab as a function of the length of the keel itself at that vertical height	Maximum allowed = 20% of correspond keel chord length at that vertical height below LWL
Maximum Weight of Trim Tab material	heaviest material from which a trim tab may be made	Maximum allowed = 708 lbs / ft ³
Maximum Weight of Winglets	heaviest material from which a winglet may be made	Maximum allowed = 518.2 lbs / ft ³
Minimum Taper Ratio of Winglets	minimum ratio of tip chord / root chord for a winglet	Minimum allowed = 0.25
Maximum Thickness Coefficient of Winglets	maximum ration of winglet thickness to winglet chord length at the corresponding distance from the keel centerline	Maximum allowed = 15% of chord length
Minimum Weight of Rudder Post	minimum weight of rudder post for rudder mounted near aft end of LWL	minimum allowed = 100 lbs
PIPA	minimum value per Appendix 2	minimum allowed = 0.0117

APPENDIX 5**Major Design Parameter Limits List for Metric Units**

MESUREMENT PARAMETER	DESCRIPTION	LIMIT
LWL	Line of Flotation in Measurement Trim	$(1.08 * R + 0.914) \leq LWL \leq (1.08 * R + 1.524)$
QBL	Quarter Beam Length	Penalty if > $\frac{100 - \sqrt{\frac{LWL}{0.3048}}}{100} * LWL + 1.018$
Forward end QBL	Forward end of QBL	Not to be taken as further aft than $0.12 * LWL$
BWL	Maximum Beam along LWL	See Limit on B just below
B	Equal to BWL as defined just above	$(0.235 * LWL) \leq B \leq (0.25 * LWL)$
FWD	Breadth at +0.400 ft WL at fwd end LWL	Penalty if > $(0.04 * LWL)$
AFT	Breadth at +0.400 ft WL at aft end LWL	Penalty if > $(0.14 * LWL)$
DISP	Displacement in Measurement Trim	Penalty if < $(0.2 * LWL + (0.5 * 0.3048))^3$ in m ³
Draft	Maximum depth of boat incl keel	Penalty if > $0.16 * LWL + 0.7803$ m
Fmin	Minimum Freeboard	Penalty if < limits in (20), (21), or (22) page 11
Stem Angle	Angle of Stem to LWL at line of flotation	Penalty if < 12.90 degrees
Counter Angle	Angle of Counter to LWL at line of flotation	Penalty if < 9.75 degrees
Tumble home	amount per side by which deck is narrower than maximum beam at that vertical location	Penalty if > 97.5 mm
Rig Height	Height of upper P band above deck at side of boat opposite mast	maximum allowed = $1.85 \sqrt{S} + 1.524$
Mainsail Max Girth	maximum dimension perpendicular to luff of sail at height = $0.65 * P$	maximum allowed = $0.56 * E$
Headboard length	length of headboard at longest point	maximum allowed = 0.427 m
Maximum Height	Maximum height of halyard sheave	maximum allowed = 25.146 m

of Fore Triangle	intersection above sheer line	
Max height of Spin Halyard	Max height of Spinnaker halyard above top of I dimension	maximum allowed = 152.4 mm
Max length of spinnaker pole	maximum length of spinnaker pole from inboard end to bearing point of guy	max allowed = $1.10 * J$
min weight mast	minimum weight of mast in specified condition	minimum = 385.5 kg
max mast motion	maximum fore/aft motion of mast at deck	maximum allowed = 101.6 mm
max boom width	maximum width of boom at any location	maximum allowed = 762 mm
max boom depth	maximum depth of boom at any location	maximum allowed = 419 mm
rudder aft of LWL	maximum distance leading edge of rudder or post can be aft of aft end of LWL	maximum allowed = 38.1 mm
Rudder Depth	maximum depth of rudder below LWL	maximum allowed = $0.5 * \text{Maximum Draft}$
Maximum Keel Taper Ratio	maximum ration of keel tip chord / keel root chord	maximum allowed = 2.0
Centerboard / Daggerboard max depth	maximum draft of a boat below LWL with a centerboard or daggerboard fully extended	maximum allowed = $1.43 * \text{Maximum Draft}$ with centerboard or daggerboard not extended
Centerboard / Daggerboard max area	maximum exposed area of a centerboard or daggerboard with that board fully extended	maximum allowed = $0.128 * \text{LWL}$ (area in m ²)
Maximum Weight of Keel material	heaviest material from which a keel may be made	maximum allowed = 11,341 kg / m ³
Maximum Chord Length of Trim Tabs	longest horizontal dimension of a trim tab as a function of the length of the keel itself at that vertical height	Maximum allowed = 20% of correspond keel chord length at that vertical height below LWL
Maximum Weight of Trim Tab material	heaviest material from which a trim tab may be made	Maximum allowed = 11,341 kg / m ³
Maximum Weight of Winglets	heaviest material from which a winglet may be made	Maximum allowed = 8300 kg / m ³
Minimum Taper Ratio of Winglets	minimum ratio of tip chord / root chord for a winglet	Minimum allowed = 0.25

Maximum Thickness Coefficient of Winglets	maximum ration of winglet thickness to winglet chord length at the corresponding distance from the keel centerline	Maximum allowed = 15% of chord length
Minimum Weight of Rudder Post	minimum weight of rudder post for rudder mounted near aft end of LWL	minimum allowed = 45.3 kg
PIPA	minimum value per Appendix 2	minimum allowed = 0.0117

This page intentionally left blank.